

TFH-18 DIMENSIONS

Influent Connection	2" FPT
Effluent Connection	2" FPT
Backwash Connection	2" FPT
A Vessel OD	18"
a Flange OD	24"
B Overall Length	41"
b Base Length	38"
C Overall Width	25"
c Base Width	16.75"
D Vessel to Influent ϕ	19"
E Grade to Influent ϕ	14.5"
F Grade to Effluent Valve ϕ	24"
G Eff Valve ϕ to BW Valve ϕ	15"
H Overall Height	61.5"

NOTE: All dimensions are approximate and must be field verified.

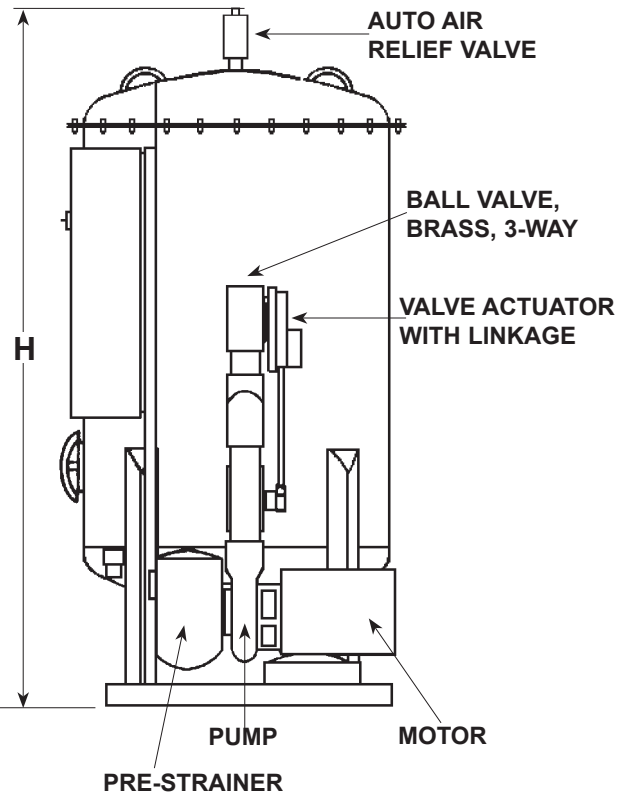

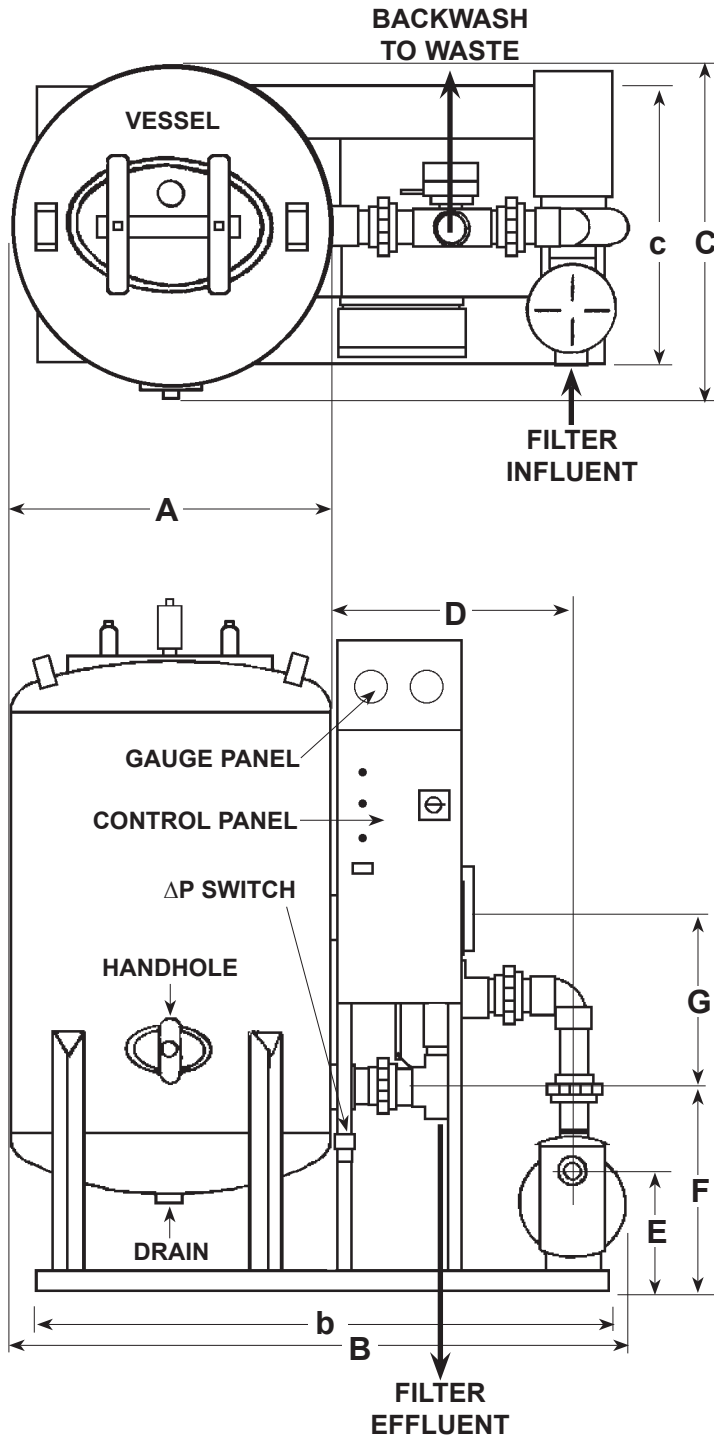

DIMENSIONS	24	30
Influent Connection	2" FPT	
Effluent Connection	2" FPT	
Backwash Connection	2" FPT	
A Vessel OD	24"	30"
B Overall Length	49"	55"
b Base Length	46"	52"
C Overall Width	28"	34"
c Base Width	22"	26"
D Vessel to Influent ϕ	19"	19"
E Grade to Influent ϕ	12"	12"
F Grade to Effluent Valve ϕ	20.5"	20.5"
G Eff Valve ϕ to BW Valve ϕ	15"	15"
H Overall Height	59"	65"

NOTE: All dimensions are approximate and must be field verified.

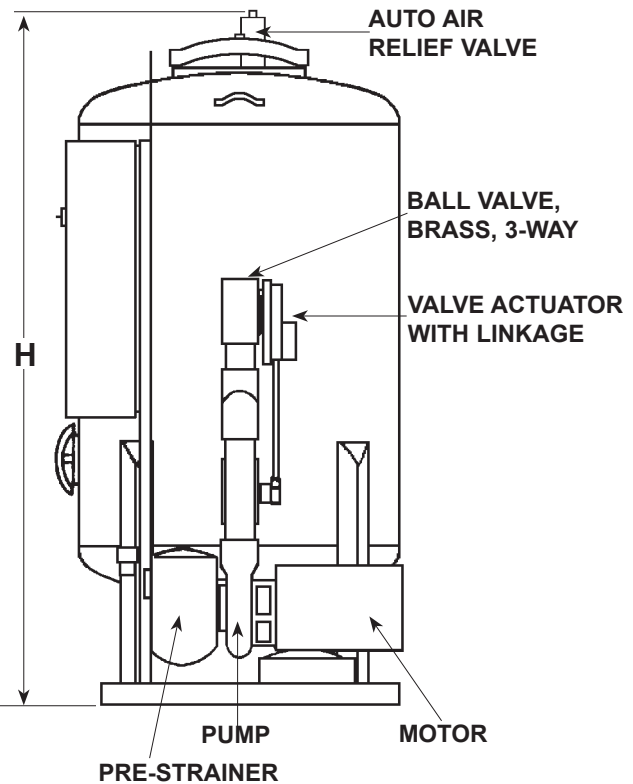

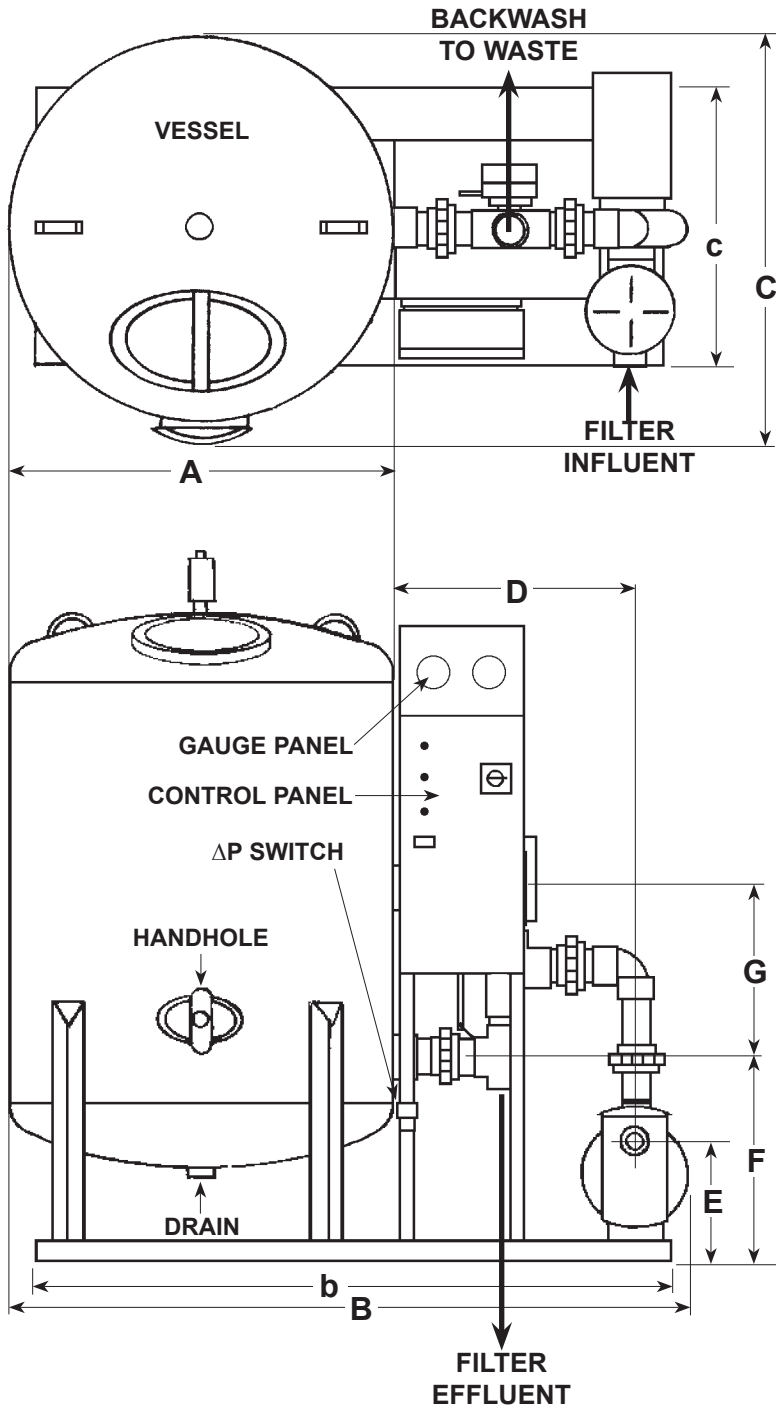

TFH-36 DIMENSIONS

Influent Connection	2.5" Flanged
Effluent Connection	2" FPT
Backwash Connection	2" FPT
A Vessel OD	36"
B Overall Length	62"
b Base Length	58"
C Overall Width	40"
c Base Width	30"
D Vessel to Influent ϕ	20.5"
E Grade to Influent ϕ	11"
F Grade to Effluent Valve ϕ	19.5"
G Eff Valve ϕ to BW Valve ϕ	15"
H Overall Height	61"

NOTE: All dimensions are approximate and must be field verified.

