

* STANDARD FEATURES *

- Removes separable solids larger than 50 micron (325 mesh) and 20% heavier than liquid
- Accommodates flow rates from 335 to 615 US GPM
- 150 PSI working pressure
- Carbon steel construction
- Fully pressure tested
- Support Legs

* AVAILABLE OPTIONS *

- Inlet/Outlet Pressure Gauges
- Clean Out Port
- Automatic purge valve with timer
- ASME certified for 150 PSIG @ 210°F
- 304 or 316 Stainless Steel construction

* PRESSURE DROP *

To determine pressure drop (PSI) at known flow rates, use the following formula:

$$\Delta P = \left(\frac{\text{GPM}}{194} \right)^2$$

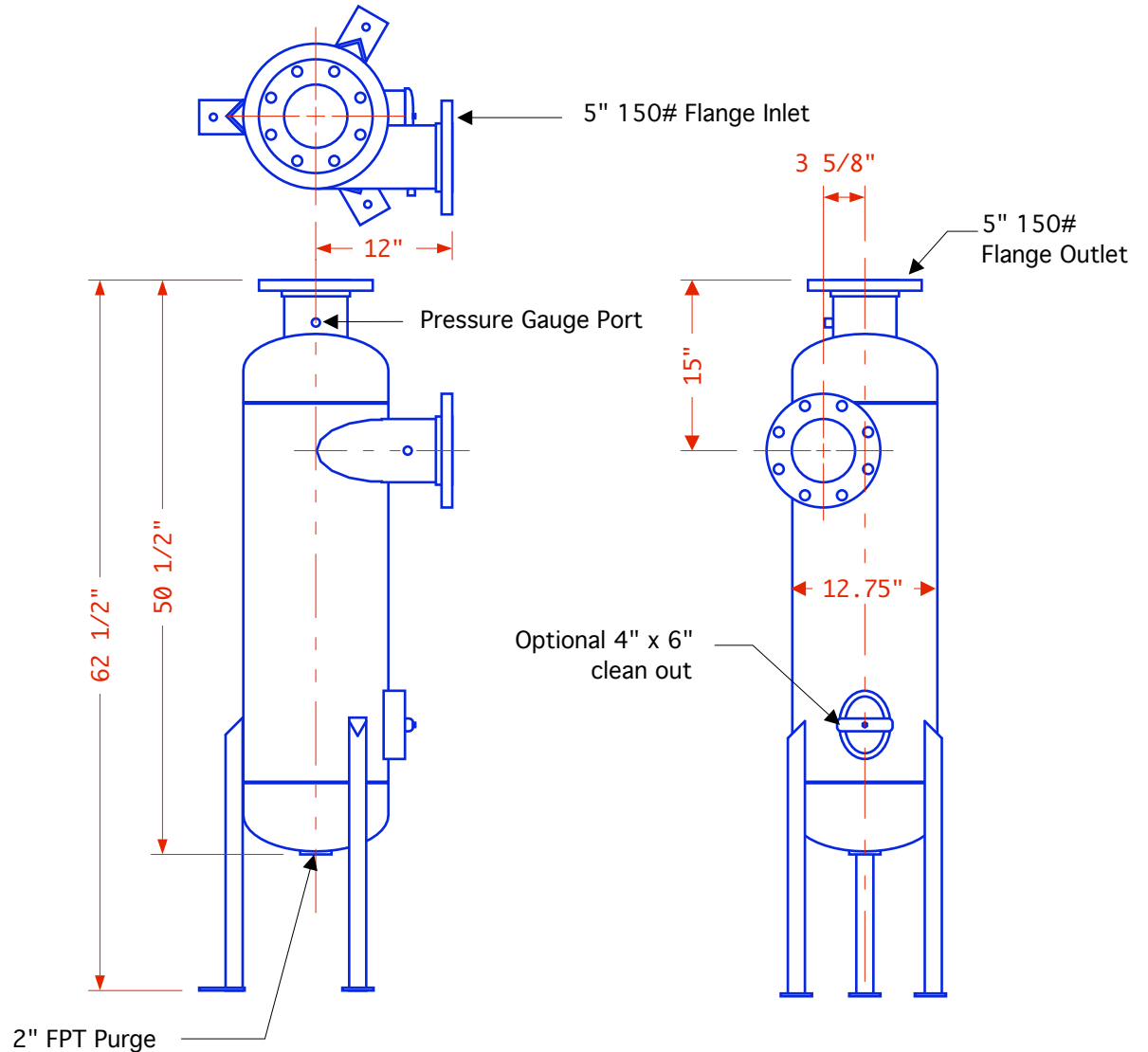

Weight (empty): 306 lbs
 Weight (full): 492 lbs
 Volume: 22.3 gallons

Note - All dimensions are approximate and are subject to change without notice.



TITLE: TFS-0500 Centrifugal Separator

PROJECT:

DWG BY: GSB

DATE: 1/31/09