

*** STANDARD FEATURES ***

- Removes separable solids larger than 50 micron (325 mesh) and 20% heavier than liquid
- Accomodates flow rates from 125 to 240 US GPM
- 150 PSI working pressure
- Carbon steel construction
- Fully pressure tested

*** AVAILABLE OPTIONS ***

- 3" x 4" clean out port
- Bracket Mounting
- Foot Mounting
- Inlet/Outlet Pressure Gauges
- Automatic purge valve with timer
- ASME certified for 150 PSIG @ 210°F
- 304, 316 Stainless Steel construction

*** PRESSURE DROP ***

To determine pressure drop (PSI) at known flow rates, use the following formula:

$$\Delta P = \left(\frac{\text{GPM}}{75} \right)^2$$

1-1/2" FPT Purge

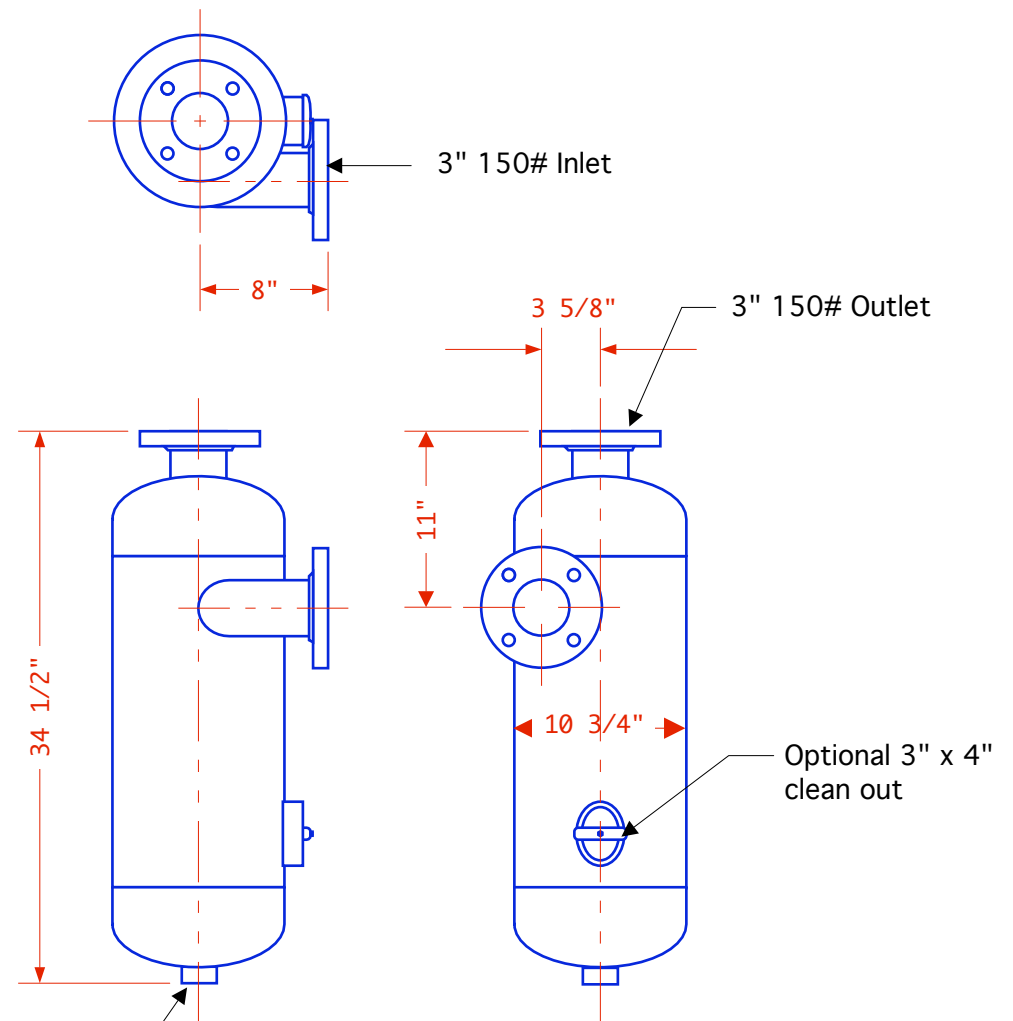

Weight (empty): 148 lbs
 Weight (full): 235 lbs
 Volume: 10.5 gallons

Note - All dimensions are approximate and are subject to change without notice.



TITLE: TFS-0300 Centrifugal Separator

PROJECT:

DWG BY: GSB

DATE: 1/31/09