

* STANDARD FEATURES *

- Removes separable solids larger than 50 micron (325 mesh) and 20% heavier than liquid
- Accommodates flow rates from 59 to 110 US GPM.
- 150 PSI working pressure
- Carbon steel construction
- Fully pressure tested

* AVAILABLE OPTIONS *

- 150# Flanged Inlet & Outlet
- Bracket Mounting
- Foot Mounting
- Inlet/Outlet Pressure Gauges
- Automatic purge valve with timer
- ASME certified for 150 PSIG @ 225°F
- 304, 316 Stainless Steel construction

* PRESSURE DROP *

To determine pressure drop (PSI) at known flow rates, use the following formula:

$$\Delta P = \left(\frac{\text{GPM}}{34} \right)^2$$

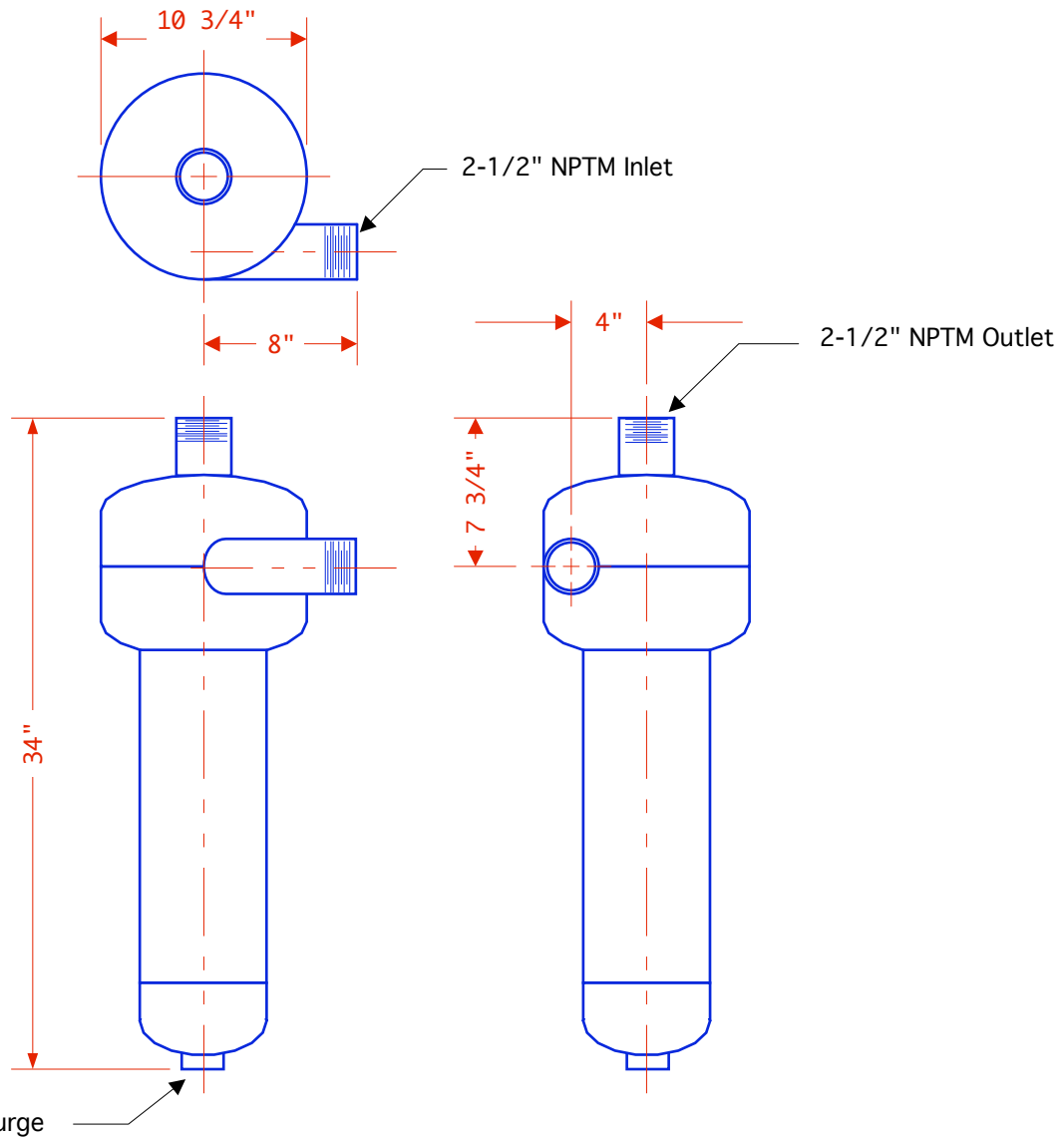

Net Weight: 68 lbs
 Weight (full): 113 lbs
 Volume: 5.5 gals

Note - All dimensions are approximate and are subject to change without notice.



TITLE: TFS-0250 Centrifugal Separator

PROJECT:

DWG BY: GSB

DATE: 1/31/09