



## TECHNICAL MANUAL

for  
Series

# TFH

*Water Filter Systems*



Complete information for

Engineering, Installation, Operation & Maintenance

of Tower-Flo® Series TFH Water Filter Systems

**UNITED**  
**INDUSTRIES**

INCORPORATED

TOWER-FLO® Division

United Industries, Inc.

P. O. Box 58

Sterling, KS 67579

800-835-3272 • 620-278-3160

Fax 800-500-3115 • 620-278-3115

[www.towerflo.com](http://www.towerflo.com)

<b>Form ID</b>	<b>Current</b>	<b>Description</b>	<b>Page</b>
TFH-INDEX	2/09	Index	2
		Warranty	3
		Warranty Registration	4
TFH-DESC	2/09	System Description	5
TFH-PSP	2/09	Project Specifications	6-8
TFH-C&D-18	5/08	Components & Dimensions, 18" Filter	9
TFH-C&D-2430	5/08	Components & Dimensions, 24" & 30" Filter	10
TFH-C&D-36	7/08	Components & Dimensions, 36" Filter	11
TFH-182430CURVE	2/07	Pump Curves, TFH-18, -24, and -30	12
TFH-36CURVE	2/07	Pump Curve, TFH-36	13
TFH-ELECT-3PH	4/10	Electrical Schematic, Three Phase	14
TFH-PTS-CNTL	2/07	Parts, Controls	15
TFH-PTS-MC	11/07	Parts, Major Components	16
TFH-PTS-SPM	11/07	Parts, Strainer, Pump & Motor TFH-18, -24, and -30	17
TFH-BW-OPS	10/02	Backwash Options	18
TFH-FWBW	2/03	Fresh Water Backwash from Municipal Supply Schematic	19
INISS	4/98	Installation Issues	20
SWEEP	4/98	Basin Sweeper Piping	21
TFH-INSTAL1	11/07	Installation Instructions	22
TFH-INSTAL2	11/07	Installation Instructions	23
TFH-INSTAL3	4/10	Installation Instructions	24
TFH-INSTAL4	7/08	Installation Instructions	25
TFH-START	10/04	Start Up Instructions	26
BLANK			27
TFH-OPER1	10/04	Operating instructions, Page 1	28
TFH-OPER2	11/08	Operating instructions, Page 2	29
TFH-MNTN	10/01	Maintenance instructions	30
TF-MEDINSP	10/01	Media Inspection Instructions	31
TFH-WINT	10/95	Winterization Instructions	32
TFH-TS	10/95	Trouble Shooting	33

Filter Model Number \_\_\_\_\_ Filter Serial Number \_\_\_\_\_

Total Filter Surface Area \_\_\_\_\_ Filtration Rate: Maximum **20** GPM/ft<sup>2</sup> of Filter Surface Area

Required clearance for service and maintenance: Vertical height \_\_\_\_\_ Horizontal width \_\_\_\_\_

Filter Flow Rate GPM: Filtration \_\_\_\_\_ Backwash \_\_\_\_\_ Maximum Working Pressure \_\_\_\_\_

**Warrant only to \_\_\_\_\_,**

the original retail purchaser, that the products which are manufactured by United Industries, Inc. are free from defects in material and/or workmanship for a period of twelve months from the date of documented installation or, in absence of documented installation date, 12 months from the date of factory shipment. The warranty registration card in this manual **MUST** be completed and returned to United Industries, Inc. in order to establish the date of installation and extend the warranty period. If, within the period provided by this warranty, any such product shall prove defective, it shall be either repaired or replaced.

For repair/replacement, the original retail purchaser shall first contact the installing dealer, as soon as possible after discovery of the defect, but in all events prior to the expiration date of the warranty. Upon notification by the dealer, United Industries, Inc., 202 East Cleveland, Sterling, Kansas 67579 will advise the purchaser of the address to which the defective item may be shipped. The serial number and the date of purchase of the item must be included. Regular UPS cost for shipping replacement part(s) to the customer will be borne by United Industries, Inc.; shipping other than regular service will be at the customer's expense. Customer is responsible for cost of shipping defective part(s) back to United Industries.

If an installing dealer was not involved, then the customer should contact United Industries, Inc.

**EXCLUSIONS**

1. This warranty shall not apply to any failures resulting from: negligence, abuse, misuse, misapplication, improper installation, alteration or modification, chemical corrosion, or improper maintenance.
2. Any items manufactured by other companies and used by United Industries in its products may carry warranties by the original manufacturers.
3. United Industries is not liable for incidental or consequential damages, loss of time, inconvenience, incidental expenses, labor or material charges in connection with removal or replacement of the equipment.

United Industries is not responsible for any implied warranties or representations by others, and the foregoing warranty is exclusive and in lieu of all warranties provided herein. Some states do not allow the exclusion or limitation of incidental or consequential damages, so the above limitation or exclusion may not apply to you. This warranty gives you specific legal rights, and you may also have other rights which vary from state to state.

**IMPORTANT**

Read and fully understand the WARNING labels on the equipment. **DO NOT OPERATE** this unit if any unsafe conditions exist.

**WARNING**

THIS FILTER SYSTEM OPERATES UNDER PRESSURE. DO NOT OPEN WHILE PUMP IS RUNNING AND/OR UNTIL ALL PRESSURE IS RELEASED THROUGH AIR RELIEF VALVE. SECURELY TIGHTEN VESSEL AND STRAINER CLAMP ASSEMBLIES ACCORDING TO MANUFACTURER'S INSTRUCTIONS. RAISE PRESSURE SLOWLY. **DO NOT EXCEED THE MAXIMUM WORKING PRESSURE OF THE VESSEL.**

**DANGER!** EXTREME CARE MUST BE TAKEN DURING PRESSURE TESTS. FAILURE TO FOLLOW THESE INSTRUCTIONS EXPLICITLY CAN RESULT IN PERSONAL INJURY.

Continuous sidestream filtration for removal of suspended solids is one, very important portion of a total water quality management program, which should also include the services of competent water treatment professionals for proper control of water hardness, pH, and biological contaminants.



# WARRANTY REGISTRATION

**EXTEND YOUR WARRANTY!**

**COMPLETE AND RETURN THIS WARRANTY REGISTRATION CARD WITHIN 10 DAYS OF  
INSTALLING YOUR FILTER TO EXTEND YOUR WARRANTY PERIOD!**

Congratulations on your selection of a TOWER-FLO® Water Filter System by United Industries, Inc.!

Your TOWER-FLO® Filter is designed and manufactured for years of virtually maintenance-free service. As with any mechanical equipment, however, components can and do fail. If you ever have a problem, Tower-Flo® is committed to supporting you and helping you get your filter back in operation as soon as possible, whether it remains under warranty or not.

Your TOWER-FLO® Filter is covered by a limited warranty as stated on the previous page. This warranty is for 12 months from the date of documented installation or, in the absence of documented installation date, 12 months from the date of factory shipment. **In order to receive the maximum warranty benefit, you must complete and return the Warranty Registration Card below within 10 days of installation to register your warranty and ensure your warranty rights.** Failure to complete and return this Warranty Registration Card will result in your warranty being limited to 12 months from the date of factory shipment.

**For Your Records**

Date of Installation \_\_\_\_\_ Date Warranty Registration Card Mailed \_\_\_\_\_

Complete the card below. Cut along dotted line. Return to:

Warranty Registration  
Tower-Flo® Filter Division  
United Industries, Inc.  
P. O. Box 58  
Sterling, KS 67579



## Manufacturer's Warranty Registration

Filter Serial Number: \_\_\_\_\_

Purchased by: Company: \_\_\_\_\_

Address: \_\_\_\_\_

City: \_\_\_\_\_ State: \_\_\_\_\_ Zip: \_\_\_\_\_

Contact Person: \_\_\_\_\_ Phone: \_\_\_\_\_

Date of Installation: \_\_\_\_\_



Series  
**TFH**

## System Description

The information below provides a general description of the main components of Series TFH filter systems. Details of standard, optional, and additional components are found in the **Project Specifications** document, on the following pages.

### MAIN COMPONENT DESCRIPTION

#### A. HIGH RATE SAND FILTER VESSEL

This permanent media, high-rate sand filter is a vertical pressure vessel constructed of epoxy lined carbon steel designed for a maximum working pressure of 100 psi with a special influent baffle in the top of the tank, a bed of filter sand and a mechanical underdrain system which collects the filtered water and directs it to the return piping system. The filter operates under pressure. When closed properly and operated without air in the water system, this filter will operate safely. The system is equipped with an automatic air relief valve and 0-160 psi influent and effluent pressure gauges mounted in a common panel.

#### B. VALVE ASSEMBLY

The valves are brass, 3-way ball valves with a single, 24VAC electric actuator and mechanical linkage.

#### C. CONTROL PANEL

The control panel provides all controls for automatic backwash operation. The standard control panel is UL® and cUL® Labeled in a NEMA 4X corrosion resistant fiberglass enclosure. Backwash is initiated by: 1) differential pressure switch (external to the enclosure); 2) manual backwash pushbutton on face of control panel; or, 3) 100 hour “re-setting” timer ( $\Delta P$  switch closure or manual initiation resets timer) for backup initiation. The sequence of the operation is described under the Operation section of this manual. The controls automatically stop the system’s pump whenever valves are to be shifted which prevents water hammer, pipe flexing, and the risk of damage to collection laterals in the vessel.

#### D. PUMP

The pump on Models **TFH-18, -24, and -30** is self-priming and has a cast brass impeller, motor bracket, and volute with stainless steel fasteners to resist corrosion. The drip-proof, cool running, mechanical seal virtually eliminates burnout and provides easy access for replacement. The pump on Models **TFH-36** is flooded suction and has machined cast iron volute, bronze fittings.

#### E. MOTOR

The totally enclosed motor with its external fan-cooled construction allows for operation in noncombustible, dusty, dirty atmospheres. It is double shielded with prelubricated ball bearings on both ends, a high tensile steel shaft, enclosed in a heavy gauge rolled steel case and is rated at a service factor of 1.15 at 40° C over ambient. Motors are UL approved and CSA stamped.

#### F. STRAINER

The pump suction strainer assembly on Models **TFH-18, -24, and -30** has a cast brass body, brass lid, and a cyclo-lac strainer basket. The lid is held in place by two brass lockhandles and includes an o-ring for positive seal.

The pump suction strainer on Model **TFH-36** has a cast iron body; stainless steel basket; cast iron cover with gasket, held in place with a yoke and bolt clamp.

#### G. MEDIA

Filter media is shipped with the unit for field installation. The filter media is quartzite or silica with a relative size of .45 to .55 mm. Clean filter media will remove particles 20 microns in size and larger. Accumulated material on the top of the media bed, called a filter cake, contributes to finer particle removal as the filter becomes “dirtier”. Removal of over 99% of 10 micron particles and 90% of 5 micron particles can be expected over the course of a filter cycle.



United Industries, Inc.  
P.O. Box 58  
Sterling, KS 67579  
800-835-3272 • 620-278-3160  
Fax 800-500-3115 • 620-278-3115  
www.towerflo.com

Form TFH-DESC:2/09

Data presented here is the best available at the time of publication. United Industries and/or its representatives assume no liability for its use.



Series  
**TFH**

# Project Specifications

**141 GPM MAX FLOW RATE      100 PSI WORKING PRESSURE**

Model Number	Base Dimensions	HP	Max GPM	TDH Ft.	Full Load Amp Draw								Media		Operating Weight in Lbs
					Single Phase				Three Phase				Area SqFt	Vol CuFt*	
					S.F.	115V	208V	230V	S.F.	208V	230V	460V			
<b>TFH-18</b>	16.75" x 38"	1	35	65	1.15	12.0	6.6	6.0	1.15	3.2	3.6	1.8	1.8	4.0	2488 2957 3910
<b>TFH-24</b>	22" X 46"	1.5	65	50	1.0	17.0	8.8	8.5	1.15	4.4	4.2	2.1	3.14	7.0	
<b>TFH-30</b>	26" X 52"	3	100	45	1.0	-	14.0	14.2	1.15	8.1	8.0	4.0	5.0	9.0	
<b>TFH-36</b>	30" X 58"	3	141	53	1.15	-	-	-	1.15	9.1	8.3	4.1	7.0	14.0	

\*1 Cubic foot of media = 100 lbs.

TOWER-FLO® Series TFH self-contained filter plants shall consist of the following major components: base, pump, motor, strainer, facepiping, valve, controls, and filter vessel. The system shall be shipped as a complete factory assembled and tested unit. Filter media shall be shipped with the unit for field installation.

Project: \_\_\_\_\_ Date: \_\_\_\_\_

The TOWER-FLO® Series TFH Model being specified for this project is a TFH-\_\_\_\_ with a maximum filter rate of \_\_\_\_ GPM. \_\_\_\_ unit(s) is(are) specified and each unit shall be equipped with the following components:

**COMPONENT SPECIFICATION**

**BASE**      \_\_\_ **Standard:** Structural steel channel and plate, primed and coated.

**PUMP**      \_\_\_ **Standard: TFH-18, -24, -30:** Self-priming, close grain cast and machined brass volute, impeller, and pump-to-motor coupling; close coupled to the motor; and capable of \_\_\_\_ GPM at \_\_\_\_ feet TDH.  
 \_\_\_ **Standard: TFH-36:** Flooded suction, machined cast iron volute, bronze fitted, close coupled to the motor and capable of \_\_\_\_ GPM at \_\_\_\_ feet TDH.  
 \_\_\_ **Option: TFH-36:** Self-priming pump, machined cast iron volute, bronze fitted, close coupled to the motor and capable of \_\_\_\_ GPM at \_\_\_\_ feet TDH.

**MOTOR**      \_\_\_ **Standard: TFH-18, -24, -30:** TEFC, heavy gauge rolled steel case, NEMA 56C frame, Class F insulation, double shielded prelubricated ball bearings; UL® and CSA® listed; \_\_\_\_ HP; and at the following VAC, phase and Hz: \_\_\_\_\_.  
 \_\_\_ **Standard: TFH-36:** TEFC, heavy gauge rolled steel case, NEMA 145JM frame, Class F insulation, double shielded prelubricated ball bearings; UL® and CSA® listed; \_\_\_\_ HP; and at the following VAC, phase and Hz: \_\_\_\_\_.  
 \_\_\_ **Option:** 575V.

**STRAINER**      \_\_\_ **Standard: TFH-18, -24, -30:** Basket type, brass body, ABS basket, brass cover with o-ring, held in place by two brass lockhandles.  
 \_\_\_ **Option: TFH-18, -24, -30:** Delete strainer on installations where inlet pressure exceeds 30PSI.  
 \_\_\_ **Standard: TFH-36:** Cast iron body; stainless steel basket; cast iron cover with gasket, held in place with a yoke and bolt clamp (60 PSI @ 150° F).

**FACEPIPING**      \_\_\_ **Standard:** Steel; backwash sight glass; influent / effluent pressure gauges, 0-160 psi, liquid-filled  
 \_\_\_ **Option:** Type 304 Stainless Steel (with brass or stainless steel valves).



Series  
**TFH**

# Project Specifications

## COMPONENT SPECIFICATION

---

**FACEPIPING** \_\_\_ **Option:** Fresh water backwash from municipal water supply; includes facepiping modifications, flow control valve for field installation; end-user responsible for the addition of pressure regulator (maximum 30 psi) and/or backflow preventer, if required.

\_\_\_ **Option:** Fresh water backwash from static water supply using pump to assist.

**VALVES** \_\_\_ **Standard:** Brass, 3-way ball valves, with electric actuation.

\_\_\_ **Option:** Stainless steel (with steel or stainless steel facepiping).

**CONTROLS** \_\_\_ **Standard, three phase or single phase, Automatic backwash operation:** UL® and cUL® Labeled control panel with: NEMA 4X corrosion resistant fiberglass enclosure; motor starter with thermal overload and short circuit protection; fuseless branch and control circuit protection; transformer to convert primary supply to 24 and 120 VAC control power; through-the-door power disconnect; programmable relay with adjustable timing controls for backwash steps; program protected internally against power failure; 30-second time delay in delta P switch circuit; 1-100 hour "re-setting" timer ( $\Delta P$  switch closure or manual initiation resets timer) for backup backwash initiation;  $\Delta P$  repeat closure shut-off and alarm; manual ON/OFF switch; manual backwash initiation switch; backwash counter; and differential pressure switch (external to the controls enclosure) for primary backwash initiation.

\_\_\_ **Option:** Backwash lockout between/among \_\_\_ units; to prevent simultaneous backwash of multiple filter units; 0-60 minute adjustable lockout time delay program; field connection between/among control panels by others.

\_\_\_ **Option:** Contacts for connection to BMS, additional specifications required from owner.

\_\_\_ remote indication of common alarm.

\_\_\_ remote indication of backwash in operation.

\_\_\_ remote control of pump on/off with HOA switch.

\_\_\_ other (be specific) \_\_\_\_\_.

\_\_\_ **Option:** Manual backwash; \_\_\_ single-phase; \_\_\_ three-phase.

**VESSEL** \_\_\_ **Standard:** \_\_\_" diameter, carbon steel; interior tank coating of 15-18 mil two-part epoxy; exterior tank primer of two-part epoxy after wire brush cleaning; exterior finish coating of two-part industrial and marine grade polyurethane; Schedule 80 PVC and molded cyclocac internals; **TFH-18** has removable top head for internal access with gasketed flange rings, bolts and nuts; **TFH-24, -30, -36** have 14" X 18" access manway; 4" X 6" handhole; 100 psi working pressure; fitted with tank drain, influent and effluent pressure gauges, automatic air relief valve. Maximum flow rate \_\_\_\_\_ GPM at 20 GPM per square foot filter surface area.

\_\_\_ **Option:** Type 304 stainless steel

\_\_\_ **Option:** working pressures to 150 psi.

\_\_\_ **Option:** Uniflex™ heat set PVC interior vessel lining, 60-90 mil finish thickness, 15 year limited vessel warranty.

**MEDIA** \_\_\_ **Standard:** Quartzite or silica in nature, hard, not smooth, uniformity coefficient of 1.7, relative size of .45 to .55 mm, containing no more than 5% flat particles or more than 1% clay, loam dust, or other foreign material. Media weighs 100 lbs per cubic foot.



Series  
**TFH**

# Project Specifications

## COMMON ADDITIONAL EQUIPMENT:

**NOZZLES** \_\_\_ **Sweeper-Eductor Nozzle**, 1/4" MPT, ABS plastic, quantity of \_\_\_\_.

**HOLDERS** \_\_\_ **Clip-On Nozzle Holder**, quantity of \_\_\_\_; for \_\_\_ 1-1/4"; \_\_\_ 1-1/2"; or \_\_\_ 2" PVC pipe.

**SURGE TANK** \_\_\_ **Polyethylene tank** for backwash surge capture and gravity release to closest drain:  
\_\_\_\_\_ gallon capacity, \_\_\_" diameter x \_\_\_" high, with a \_\_\_" diameter lid in top head and a 2" FPT drain bulkhead fitting.  
\_\_\_ Additional \_\_\_" bulkhead fitting for inlet from filter (2", 3", or 4"), field installed by others;  
\_\_\_ 2", 2-way, manual ball valve, \_\_\_ Sch 40 PVC, \_\_\_ Sch 80 PVC, \_\_\_ brass, for field installation by others on drain piping from tank for isolation and/or throttling.

**LIQUID LEVEL** \_\_\_ **Liquid level control assembly** for backwash surge tank to interrupt filter pump if/when surge tank nears capacity. Includes: ITT McDonnell-Miller 750B liquid level controller mounted in separate NEMA 3R enclosure requiring separate 120 V power supply factory mounted on filter's control panel bracket (unless otherwise specified); sensor; 3 trimmable probes (L, H, and Ground); field wiring from sensor to LLC enclosure by others. Also includes additional contacts for remote pump on/off in filter control panel.  
\_\_\_ Liquid level control column assembly; 2" Sch 80 piping assembly mounted on side of poly tank to isolate liquid level probes from turbulence in poly tank.

**SOLENOID VALVE** \_\_\_ **Solenoid valve**, for backwash siphon break, \_\_\_", bronze, with 24 VAC solenoid.

**NOTE:** Backwash flow rate, irrespective of water source, must be no less than 75% and no greater than 100% of the vessel's designed maximum gpm. Backwash duration is factory preset at 3 minutes and is field adjustable.



United Industries, Inc.  
P.O. Box 58  
Sterling, KS 67579  
800-835-3272 • 620-278-3160  
Fax 800-500-3115 • 620-278-3115  
www.towerflo.com

Form TFH-PSP:2/09-P3

Data presented here is the best available at the time of publication. United Industries and/or its representatives assume no liability for its use.

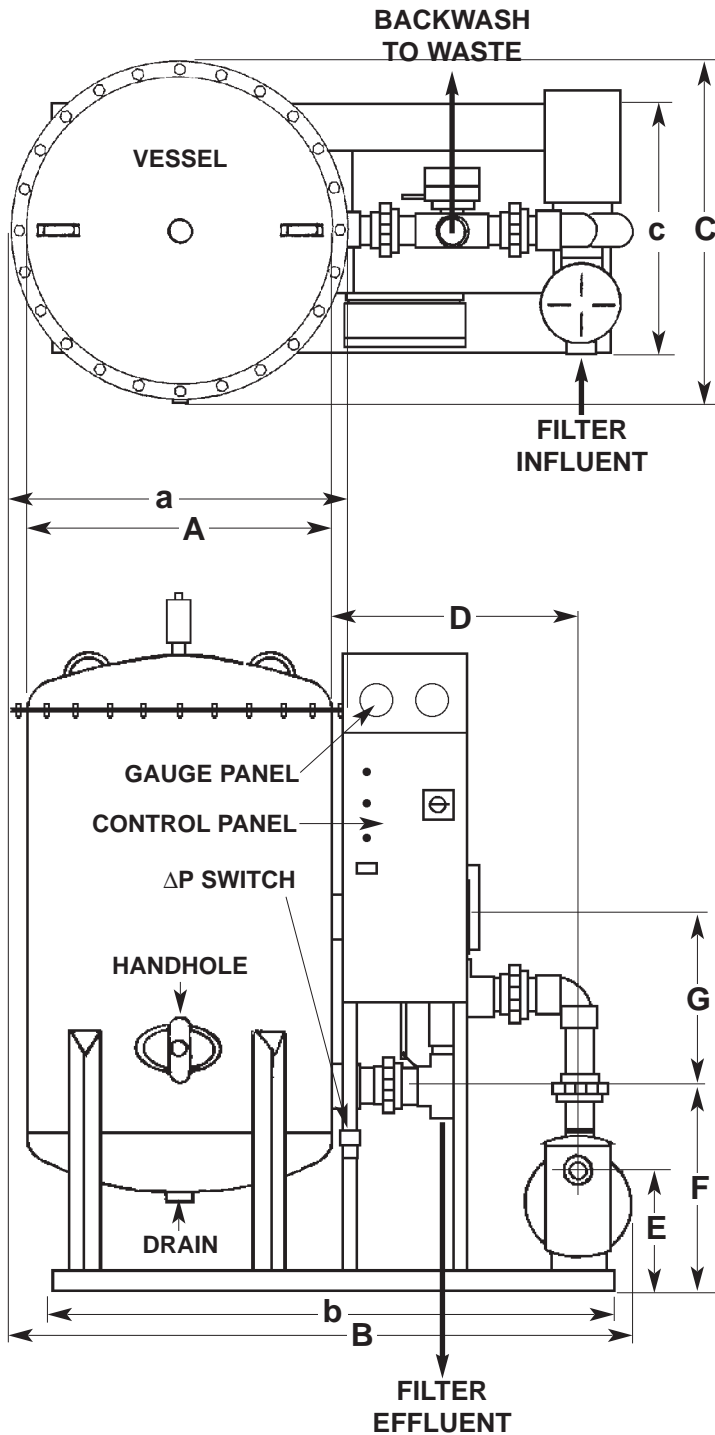

### TFH-18 DIMENSIONS

Influent Connection	2" FPT
Effluent Connection	2" FPT
Backwash Connection	2" FPT
A Vessel OD	18"
a Flange OD	24"
B Overall Length	41"
b Base Length	38"
C Overall Width	25"
c Base Width	16.75"
D Vessel to Influent $\phi$	19"
E Grade to Influent $\phi$	12"
F Grade to Effluent Valve $\phi$	24"
G Eff Valve $\phi$ to BW Valve $\phi$	15"
H Overall Height	61.5"

**NOTE: All dimensions are approximate and must be field verified.**

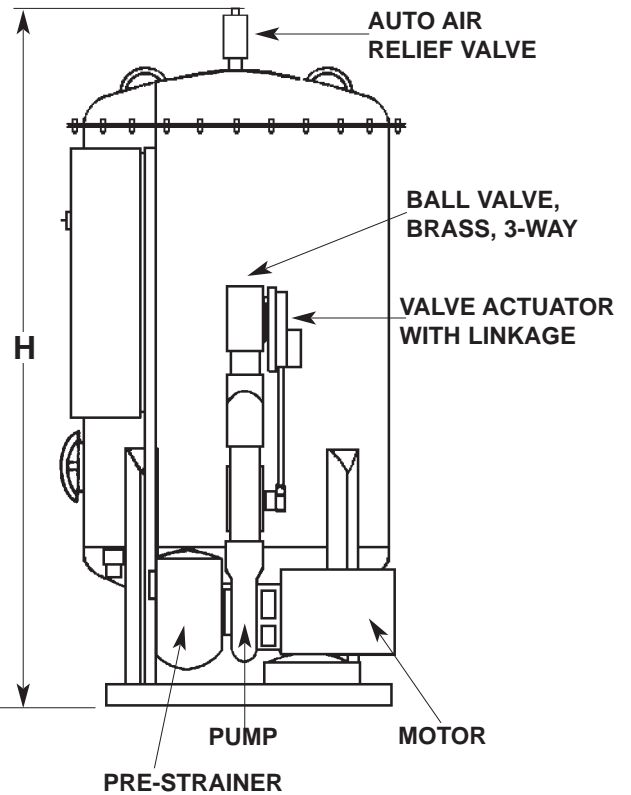

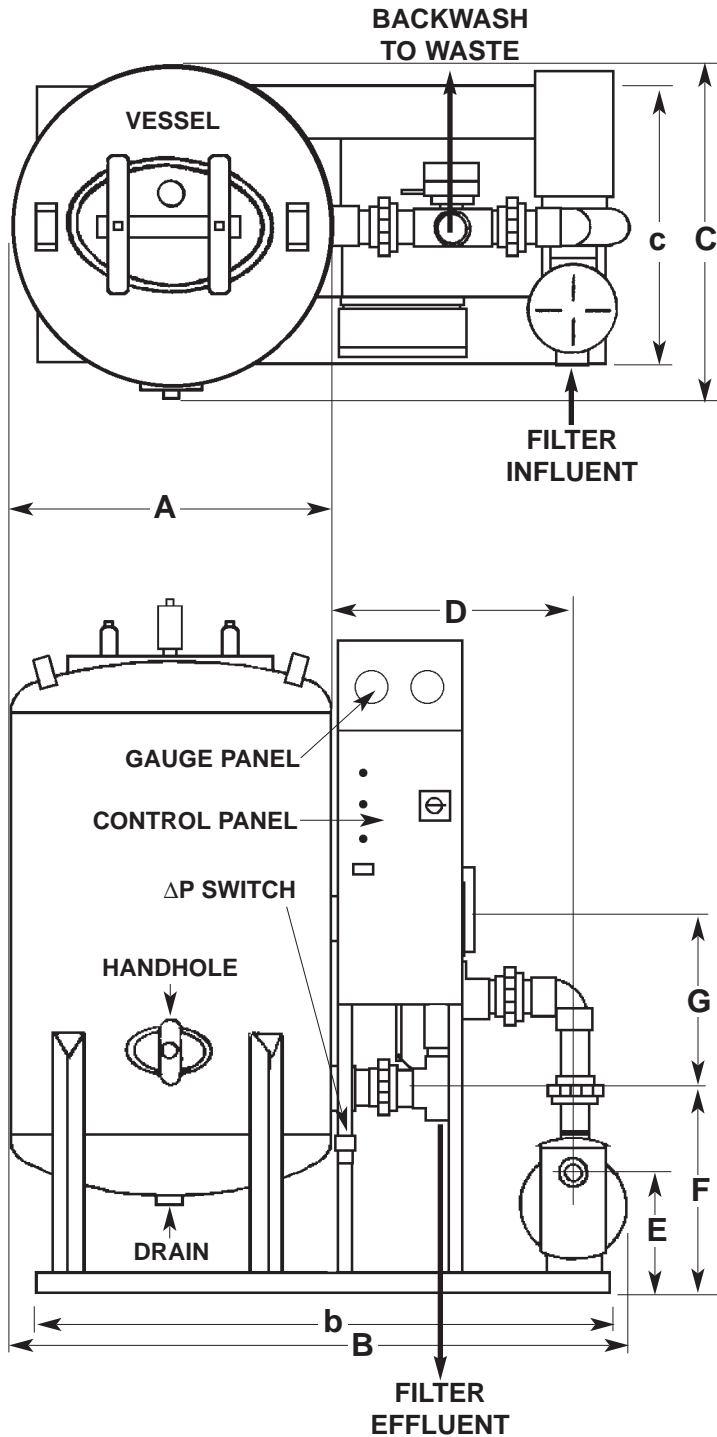

DIMENSIONS	24	30
Influent Connection	2" FPT	
Effluent Connection	2" FPT	
Backwash Connection	2" FPT	
A Vessel OD .....	24"	30"
B Overall Length .....	49"	55"
b Base Length .....	46"	52"
C Overall Width .....	28"	34"
c Base Width .....	22"	26"
D Vessel to Influent $\phi$ .....	19"	19"
E Grade to Influent $\phi$ .....	12"	12"
F Grade to Effluent Valve $\phi$ .....	20.5"	20.5"
G Eff Valve $\phi$ to BW Valve $\phi$ .....	15"	15"
H Overall Height .....	59"	65"

**NOTE: All dimensions are approximate and must be field verified.**

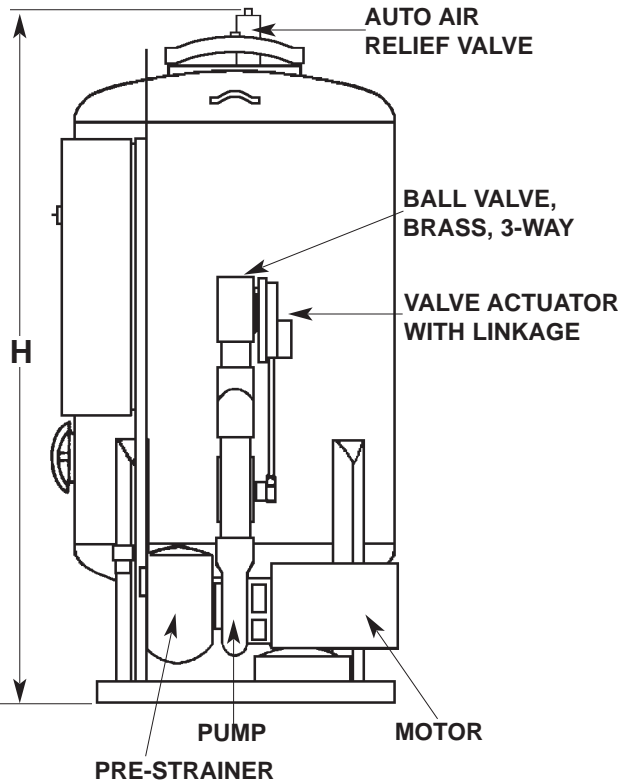

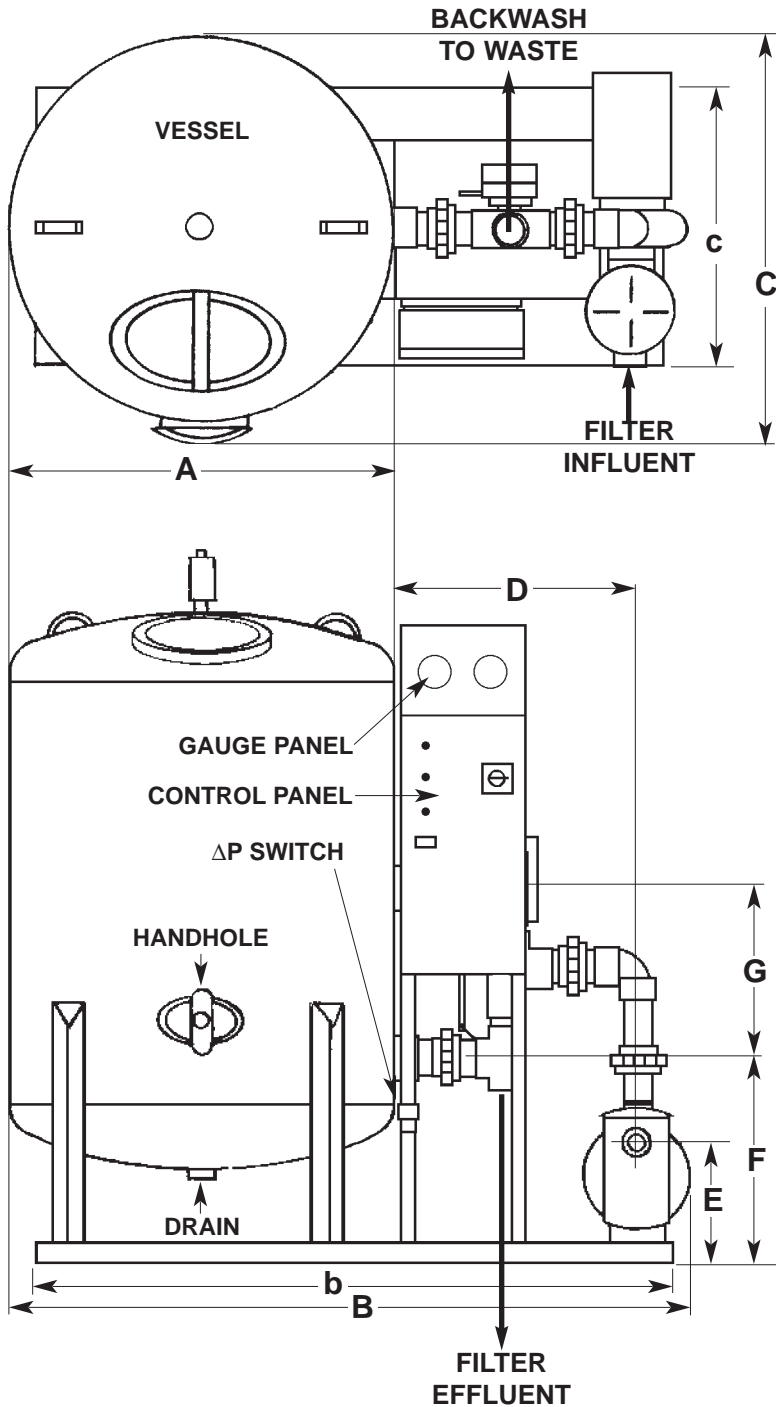

### TFH-36 DIMENSIONS

Influent Connection	2.5" Flanged
Effluent Connection	2" FPT
Backwash Connection	2" FPT
A Vessel OD	36"
B Overall Length	62"
b Base Length	58"
C Overall Width	40"
c Base Width	30"
D Vessel to Influent $\phi$	20.5"
E Grade to Influent $\phi$	13"
F Grade to Effluent Valve $\phi$	19.5"
G Eff Valve $\phi$ to BW Valve $\phi$	15"
H Overall Height	61"

**NOTE:** All dimensions are approximate and must be field verified.

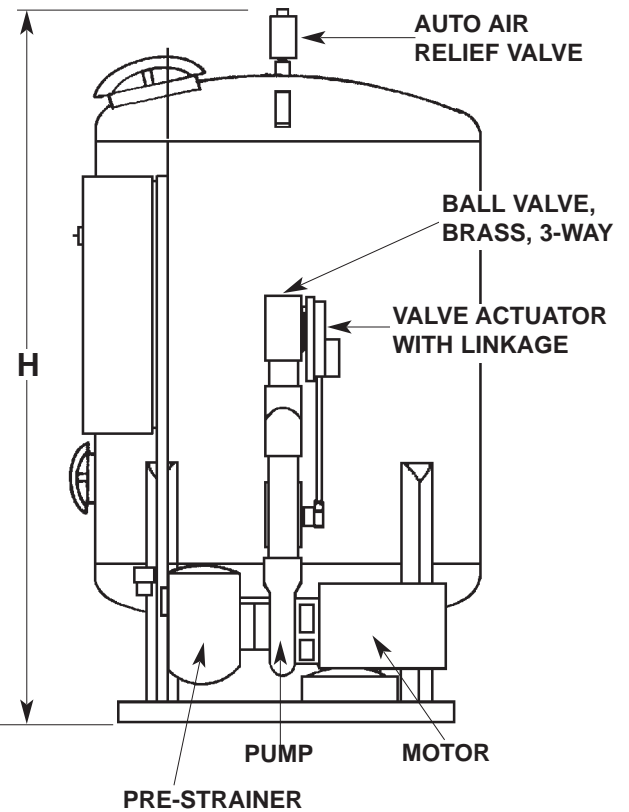



Series  
**TFH**

18, 24, 30 Pump Curve

## PERFORMANCE CURVE

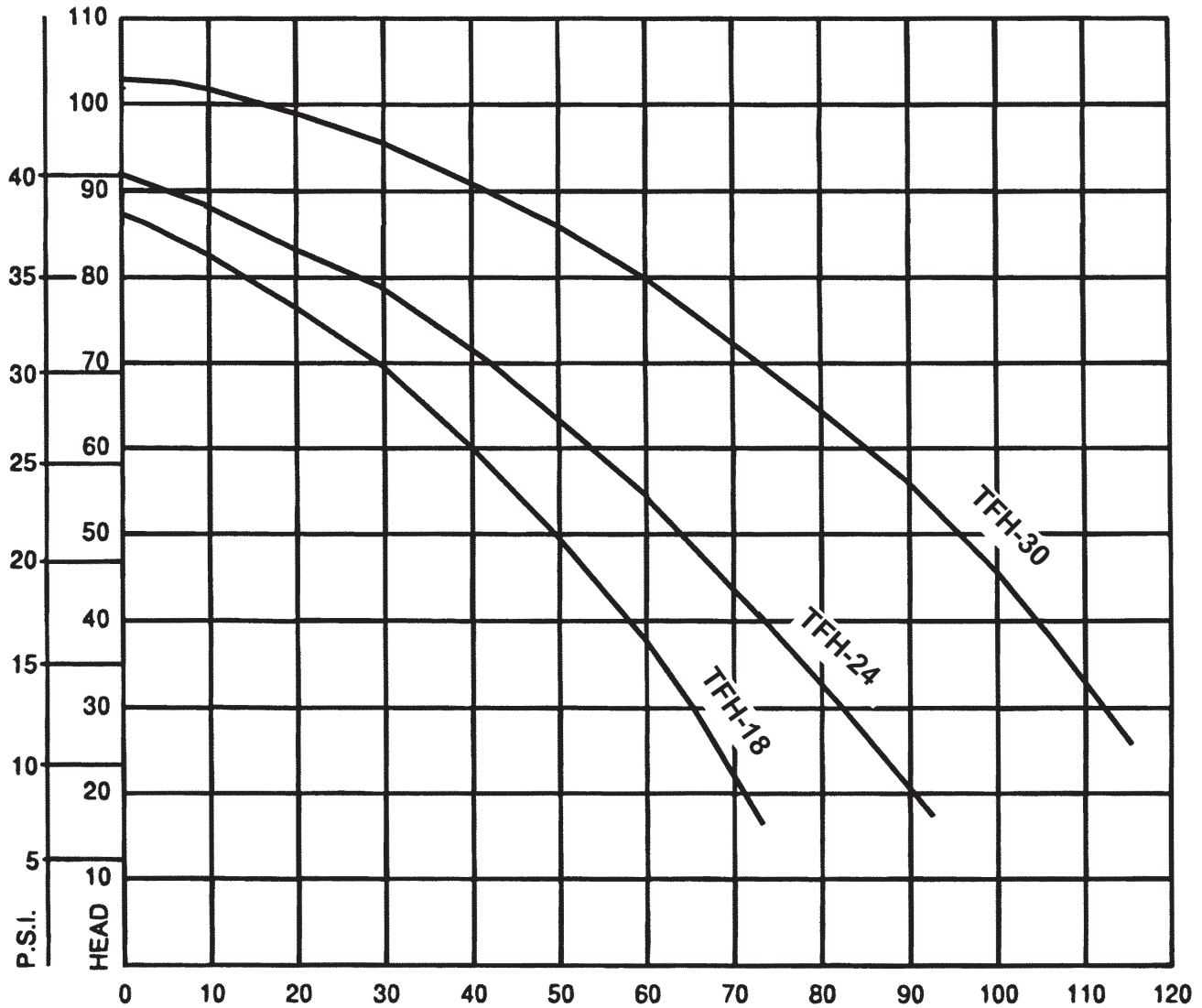

### CAPACITY IN GALLONS PER MINUTE

Curve based on 3450 RPM impeller speed. 50 cycle units available.



United Industries, Inc.  
P.O. Box 58  
Sterling, KS 67579  
800-835-3272 • 620-278-3160  
Fax 800-500-3115 • 620-278-3115  
www.towerflo.com

Form TFH-182430CURVE:2/07

Data presented here is the best available at the time of publication. United Industries and/or its representatives assume no liability for its use.

### PUMP DATA SHEET

Company: TOWER-FLO  
 PROJECT: SERIES TFH-36  
 Date: 01/09/07

**Pump:**  
 Size: 2x2.5x7  
 Type: 3340  
 Synch speed: 1800 rpm  
 Curve: PC-184523  
 Specific Speeds:  
 Dimensions:  
 Speed: 1770 rpm  
 Dia: 7 in  
 Impeller:  
 Ns: ---  
 Nsa: ---  
 Section: 2.5 in  
 Discharge: 2 in

**Search Criteria:**  
 Flow: 141 US gpm  
 Head: 53 ft

**Fluid:**  
 Water  
 SG: 1  
 Viscosity: 1.105 cP  
 NPSHa: --- ft  
 Temperature: 60 °F  
 Vapor pressure: 0.2563 psi a  
 Atm pressure: 14.7 psi a

**Pump Limits:**  
 Temperature: 225 °F  
 Pressure: 175 psi g  
 Sphere size: 0.4 in  
 Power: --- hp  
 Eye area: --- in²

**Motor:**  
 Standard: NEMA  
 Enclosure: TEFC  
 Sizing criteria: Max Power on Design Curve  
 Size: 3 hp  
 Speed: 1800  
 Frame: 182T

**--- Data Point ---**  
 Flow: 141 US gpm  
 Head: 53.5 ft  
 Eff: 86%  
 Power: 2.18 hp  
 NPSHr: 6.69 ft

**--- Design Curve ---**  
 Shutoff Head: 61.7 ft  
 Shutoff dP: 26.7 psi  
 Min Flow: --- US gpm  
 BEP: 87% eff  
 @ 153 US gpm  
 NOL Pwr: 2.68 hp  
 @ 230 US gpm

**--- Max Curve ---**  
 Max Pwr: 2.68 hp  
 @ 230 US gpm

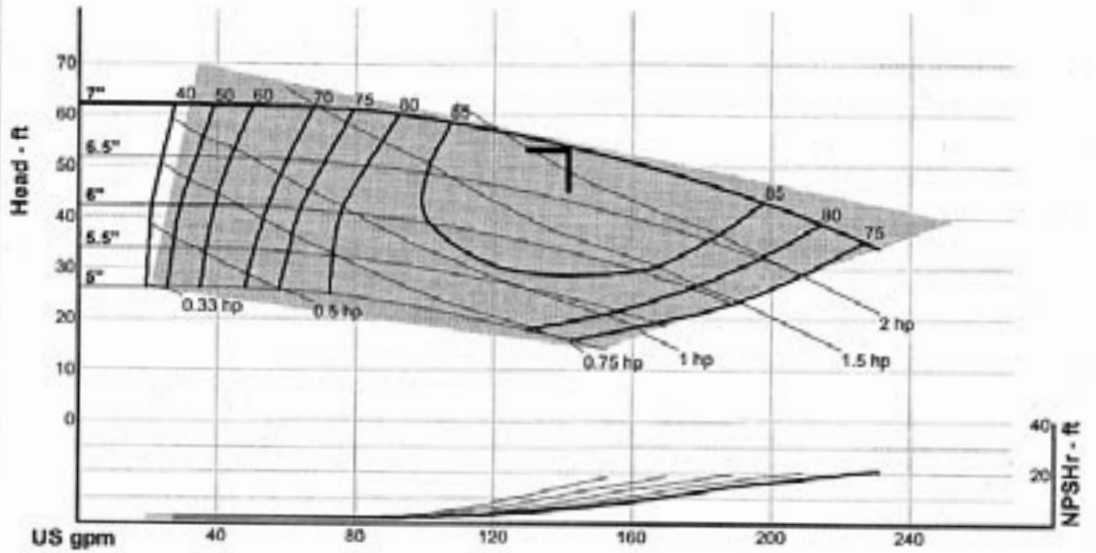

### Performance Evaluation:

Flow US gpm	Speed rpm	Head ft	Pump %eff	Power hp	NPSHr ft
169	1770	48.5	86	2.37	11
141	1770	53.5	86	2.18	6.69
113	1770	57.4	85	1.91	3.79
84.6	1770	60.3	77	1.66	2.5
56.4	1770	61.4	64	1.36	2.5



### Control Panel, Complete Assembly

P295065F	TFH -18, -24,-30 and 36, 3 phase, auto backwash (must add correct Trip Module)
P295062F	TFH -18, -24, 30 and 36, 1 phase, auto backwash (must add correct Trip Module)

### Control Panel - Major Components

Part #	Qty	Type	Description & Application
P263126	1	H-PKZ2	Handle, Disconnect Switch
P263125	1	AH-PKZ2	Shaft Extension, Disconnect Switch
P263152	1	PKZ2	Switch Module, Disconnect Switch
P263148*	*	ZM-1.6-PKZ2	Trip Module, 1.0-1.6 FLA*, Disconnect Switch
P263149*	*	ZM-2.4-PKZ2	Trip Module, 1.6-2.4 FLA*, Disconnect Switch
P263150*	*	ZM-4-PKZ2	Trip Module, 2.4-4.0 FLA*, Disconnect Switch
P263153*	*	ZM-6-PKZ2	Trip Module, 4.0-6.0 FLA*, Disconnect Switch
P263154*	*	ZM-10-PKZ2	Trip Module, 6.0-10.0 FLA*, Disconnect Switch
P263151*	*	ZM-16-PKZ2	Trip Module, 10.0-16.0 FLA*, Disconnect Switch
P263155*	*	ZM-25-PKZ2	Trip Module, 16.0-25.0 FLA*, Disconnect Switch
P295090	1	B100MBT713XK100VA	Transformer
P295191	1	M22-WKV	Selector switch operator
P295126	1	M22-D-S	Pushbutton operator
P295192	2	M22-AK10	Contact block
P295085	1	Counter	Backwash Counter

### 2/94 through 2/98

P295110	1	RTE-B21-AC24V	Timer T1
P263121	1	SR3B-05	Socket, Timer T1
P295320	2	332-24V-300	Timer T2 & T3, before 2/98
P263123	2	OT-08-PC	Socket, Timer T2 & T3, before 2/98
P295123	1	DIL00M, 24V	Motor Contactor, 24V

### 3/98 through 6/99

P295110	1	RTE-B21-AC24V	Timer T1
P263121	1	SR3B-05	Socket, Timer T1
P295118	2	RTE-P1-1-AC24V	Timer T2 & T3, after 2/98
P295119	2	TIM 51X120	Socket, Timer T2 & T3, after 2/98
P295123	1	DIL00M, 24V	Motor Contactor, 24V coil

### 6/99 through Present

P263163	1	EZ-512-AC-RC	Programmable Relay, after 6/99
P263128	1	DIL00M, 120V	Motor Contactor, 120V coil
P295080	1	DILR22	Control Relay, 120V coil
P263019	1	11 DIL	Auxillary Contact

**\*NOTE:** One thermal/magnetic trip module is provided, matched to the HP & primary voltage supply.

### Pressure Switch

M866083	Differential pressure switch
---------	------------------------------

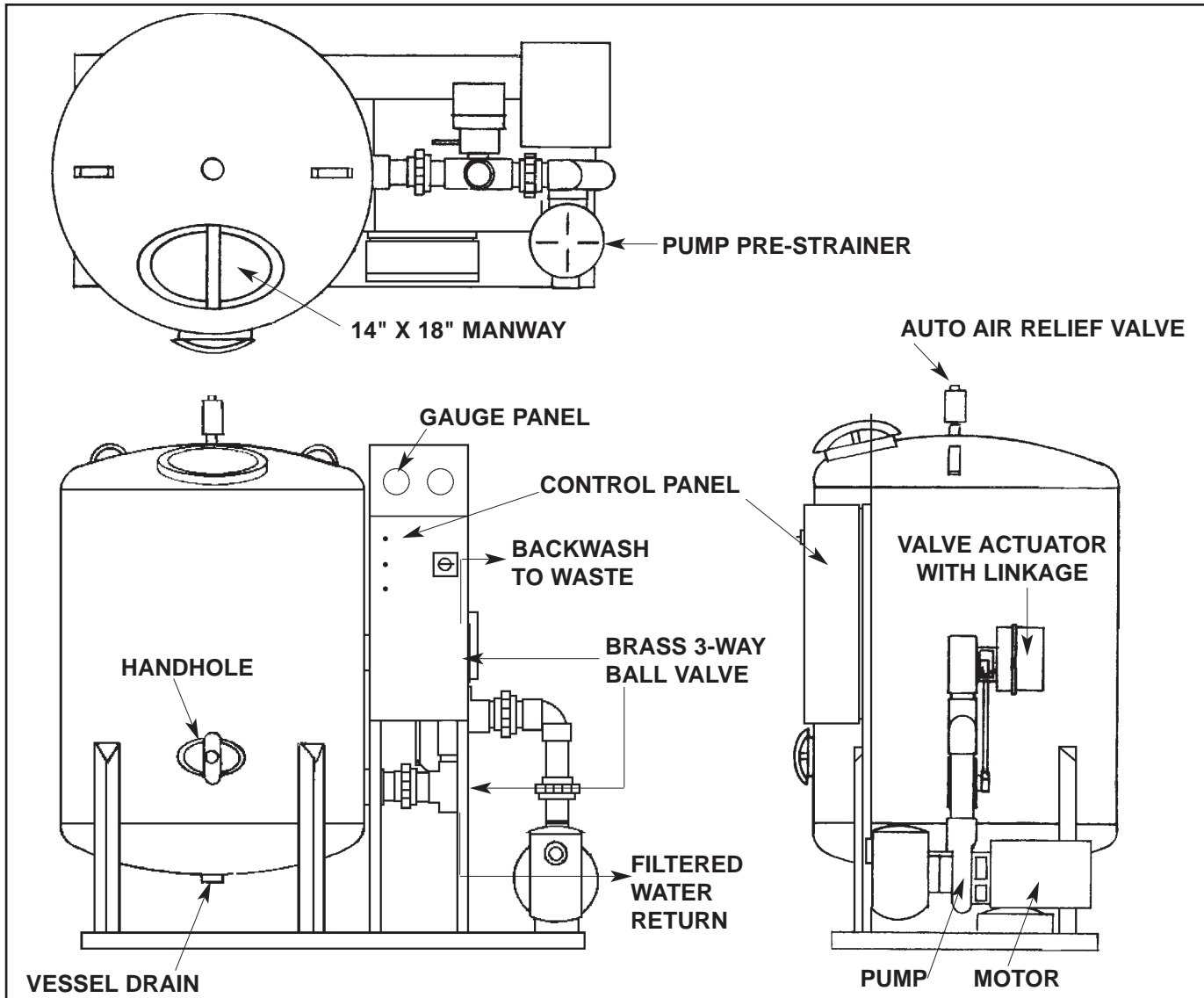

**TFH-18, top head gasket**

M846219 Gasket, 18" round

**Manway, 11" x 15" (until 11/07)**

M846310 Manway cover, 11" x 15"

**Manway, 14" x 15" (11/07 to present)**

M846394 Gasket, 14" x 18" Manway

**Handhole**

M846185 Cover, yoke, bolt and gasket

**Gauge Panel**

P181050 Complete assembly, 0-60 psi

P181060 Complete assembly, 0-160 psi

**Valve & Actuator**

M870330K Valve, ball, 3-way, brass, 2"

M870377 Actuator, electric, 24 VAC

M870376K Actuator mounting kit



Series  
**TFH** Parts-Strainer, Pump, & Motor  
 -18, -24" & -30"

**Common Part Numbers for TFH-18, -24, and -30**

Item	Part #	Description	Qty	Item	Part #	Description	Qty
1	P263165	Lockhandle, brass	2	11	P171920	Hex bolt 5/16-18 x 3/4	2
2	Z010830	Trap cover, bronze, 5"	1	12	P170415	Gasket, trap to volute	1
3	P171977	Trap cover, O-ring 5"	1	14	P170417	Volute	1
4	P171005	Basket, strainer 5"	1	16	P171976	Seal	1
5	P170422	Trap body, bronze, 5" x 2"	1	17	P171974	Gasket, volute	1
7	P263171	Plug volute and/or trap	2	18	P171903	Hex bolt, 3/8-16 x 5/8	4
8	M808698	Bolt, trap to volute	4	19	P170420	Bracket	1
9	P171915	Pump base	1	20	P171902	Hex bolt, 5/16-18 x 5/8	8
10	P171917	Lockwasher	2	21	P171901	Screws, set	3
				22	P171904	Shaft extension	1

**Uncommon Part Numbers**

	TFH-18	TFH-24	TFH-30		
15	P171971	P171972	P171973	Impeller	1
23	P171922	P171938	P171983	Pump assembly, (items 9-22)	1
24	P171942	P295056	P171541	Motor, three phase, TEFC	1

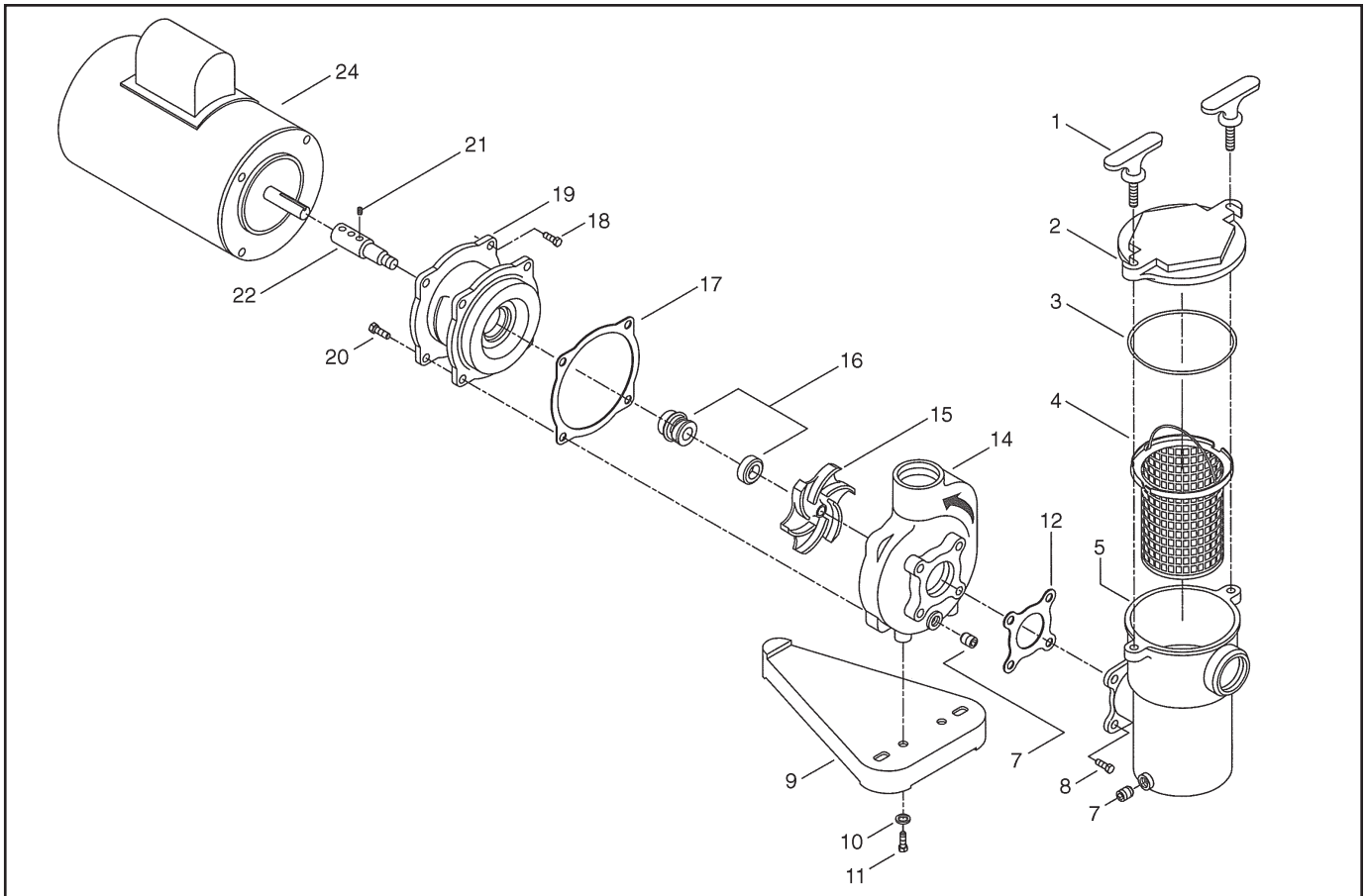

United Industries, Inc.  
 P.O. Box 58  
 Sterling, KS 67579  
 800-835-3272 • 620-278-3160  
 Fax 800-500-3115 • 620-278-3115  
 www.towerflo.com

Form TFH-PTS-SPM:11/07

Data presented here is the best available at the time of publication. United Industries and/or its representatives assume no liability for its use.



Series  
**TFH**

## Backwash Options

TOWER-FLO® Filters are equipped to automatically back wash using water from the same source they are filtering. In the vast majority of sidestream applications this is perfectly satisfactory. However, in some cases it is not desirable to dispose of system water for filter backwashing. In those cases, TOWER-FLO® offers three alternative approaches as described below.

### FRESH WATER BACKWASH FROM MUNICIPAL SUPPLY

This option uses municipal water supply for backwashing. When the filter's differential pressure switch activates backwash, the system pump is stopped for the duration of the backwash operation and a valve is opened to allow city water to backwash the vessel. The flow rate and pressure of the city water supply must be controlled so as not to exceed the limits of the vessel; conversely, the flow rate must meet the vessel's minimum backwash flow requirement of 75% of flow rate.

Ordering this option changes the facepiping from the standard configuration (as shown on pages 9, 10 & 23) to the configuration shown on the following page. Municipal water supply is connected to the bottom valve as shown. Additionally, this option provides a flow control valve, factory preset to the maximum flow rate of the vessel, to be installed on site in the municipal water supply line to the filter. **The end-user is responsible for the addition of a pressure-controlling device in the fresh water supply line set to a maximum 30 psi. Local code may also require the addition of a back flow preventer in the fresh water supply line.**

### FRESH WATER BACKWASH FROM STATIC SUPPLY, PUMP ASSISTED

This option uses some totally independent, static pressure water supply (such as an accumulation vessel) for backwashing and relies on the system pump to create the backwash flow. This option is useful when it is not desirable to backwash with system water and municipal supply is either not available or cannot meet the minimum flow requirement.

Ordering this option provides an additional three-way valve mounted to the suction port on the pump pre-strainer. The three-way valve is normally open on the suction line from source and closed to the backwash water source. It switches position simultaneously with the two backwash control valves.



United Industries, Inc.  
P.O. Box 58  
Sterling, KS 67579  
800-835-3272 • 620-278-3160  
Fax 800-500-3115 • 620-278-3115  
www.towerflo.com

Form TFH-BW-OPS:10/02

Data presented here is the best available at the time of publication. United Industries and/or its representatives assume no liability for its use.

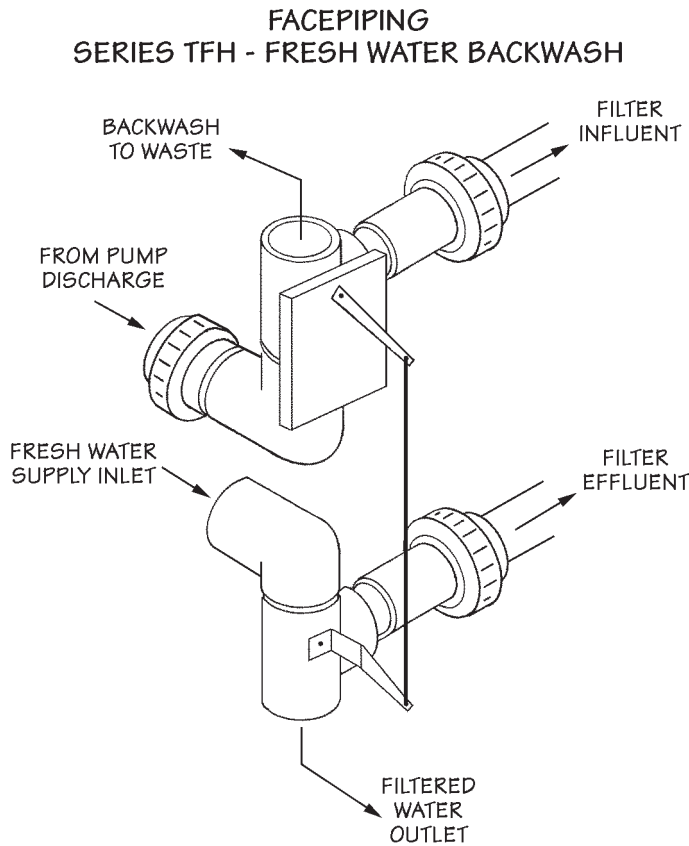

**INSTALLATION SEQUENCE - FRESH WATER BACKWASH FROM MUNICIPAL SUPPLY**

This option changes the facepiping from the standard configuration (as shown in drawings elsewhere) to the configuration shown above. Included with this option is a flow control valve for field installation. **The end-user is responsible for the addition of a pressure-controlling device in the municipal water supply line set to a maximum 30 psi. Local code may also require the addition of a back flow preventer in the municipal water supply line.**

Municipal water supply is connected to the top port of the bottom valve. The additional equipment required to control the pressure and flow of municipal water supply to the filter system should be installed in the following sequence from source toward the filter's bottom valve: 1) back flow preventer (by others); 2) pressure controlling device set to maximum 30 psi (by others); 3) flow control valve 2" (provided by TF) set at either • 28% for TFH-24 at 65 gpm, • 20% for TFH-30 at 100 gpm. • or 13% for TFH-36 at 141 gpm.



# Installation Issues

## INSTALLATION STYLE

Tower-Flo® generally recommends **sidestream** installation of its filter systems and its standard systems are designed and built for **sidestream** application. **Sidestream** filtration means a filter system which draws water from and returns it to a static pressure reservoir of water in the cooling loop, completely independent of the cooling water recirculation system. Usually, that reservoir of water is the basin of the cooling tower or sometimes it may be a chilled water storage reservoir in the cooling loop.

However, there are occasions where a design has called for **slipstream** installation. **Slipstream** filtration means a filter which is installed on the pressurized recirculation piping system, "slipping" a portion of the chilled water recirculation flow through the filter system. Depending on the points of connection to the recirculation piping, the **slipstream** may be either under the influence of the discharge side or the suction side of the recirculation pump.

**If the filter system you are about to install is to be installed in any other fashion than sidestream, please be sure that necessary consideration has been given to operating pressure of the filter system and flow promotion issues. If you, as the installer, have any questions, contact your local Tower-Flo® Representative or contact the Tower-Flo® Water Filter Systems Division of United Industries, Inc.**

## BASIN SWEEPER PIPING SYSTEM

A basin sweeper piping system will use the return flow of filtered water from the filter system to help sweep solids towards the filter's suction point. However, it is very important to have a reasonable expectation of such a basin sweeper piping system. It must be understood that the primary purpose of the filter system is the continuous removal of suspended solids from the water being recirculated through the cooling loop. The basin sweeper piping system provides a secondary benefit by promoting the movement solids across the basin floor toward the filter suction point for removal.

While such a system can reduce the time and effort required for regular basin clean-out, even the best designed sweeper piping system cannot keep a cooling tower basin perfectly clean nor sweep effectively around all appertances. If you plan to use a basin sweeper piping system, please review the information on the next page to determine the proper number of nozzles or perforations to be used with your basin sweeper piping system.

**IF YOU, AS THE INSTALLER OR OWNER OR OPERATOR, HAVE ANY QUESTIONS ABOUT ANY ASPECT OF YOUR INSTALLATION AND/OR OPERATION OF THIS TOWER-FLO® FILTER SYSTEM, CONTACT YOUR LOCAL TOWER-FLO® REPRESENTATIVE OR CONTACT THE TOWER-FLO® WATER FILTER SYSTEMS DIVISION OF UNITED INDUSTRIES, INC., BEFORE START-UP OF THIS FILTER SYSTEM.**



United Industries, Inc.  
P.O. Box 58  
Sterling, KS 67579  
800-835-3272 • 620-278-3160  
Fax 800-500-3115 • 620-278-3115  
www.towerflo.com

Form INISS:4/98

Data presented here is the best available at the time of publication. United Industries and/or its representatives assume no liability for its use.



# Basin Sweeper Piping

**DISCHARGE OPENINGS:** The sizing of holes in a basin sweeper piping system evolves from the decision of the *type* of DISCHARGE openings to be used; either simple holes, sweeper-educator nozzles, or a combination of those two types. Different criteria must be used to determine the number of discharge holes and/or nozzles to be used for a given application, as follows:

**HOLES ONLY:** The total open area of discharge line openings should be equal to or slightly greater than the total open area of the discharge pipe size. Use the table or the formula below to determine the size and number of holes to be used.

**NOZZLES ONLY:** The total number of nozzles will be the flow rate of the filter system divided by 5 gpm per nozzle.

**COMBINATION OF NOZZLES & HOLES:**

- 1) start with the filter flow rate.
- 2) determine the preliminary number of nozzles you want to use.
- 3) multiply that number of nozzles by 5gpm per nozzle.
- 4) subtract the outcome of 3) from the total flow rate of the filter system (this is the portion of the filter flow rate consumed by nozzles; this number cannot exceed the filter's flow rate; if it does, return to the nozzle only instructions).
- 5) divide the remaining flow rate by 3 gpm to determine the number of **1/4"** holes to be used in conjunction with the nozzles.

**SUCTION OPENINGS:** Irrespective of the *type* of discharge openings selected, the number and size of suction openings will **always** be determined by the following: the total open area of suction line openings should be equal to or slightly greater than 125% of the total open area of the discharge pipe size.

**TO CALCULATE NUMBER AND SIZE OF DISCHARGE AND SUCTION OPENINGS**

- Steps:
- 1 Calculate open area of selected discharge pipe size based on its inside diameter ( $\pi r^2$ );
  - 2 Calculate open area of selected discharge hole size ( $\pi r^2$ );
  - 3 Divide result of Step 1 by result of Step 2 to find number of holes in discharge piping (round up);
  - 4 Multiply result of Step 3 by 1.25 to find number of suction holes (round up).

The calculated number of discharge openings should be spaced evenly around the discharge pipe run or across pipe runs designed to influence specific areas. Suction holes should be spaced evenly around the suction header in the water basin or reservoir. Common sense should always govern the selection of hole sizes, the resulting number of holes, and the placement of those openings; keep the number of holes to be drilled to a practical, manageable number for the run of pipe.

The tables below will help you select the size and number of holes for most Series TF, TFD, TFD2, and TFH installations. The Inside Diameter Table provides the information necessary for you to calculate hole sizes and number for other installations.

Inside Diameter of Common Pipe Sizes							
	1.5"	2.0"	2.5"	3.0"	4.0"	6.0"	8.0"
Sch 40	1.610	2.067	2.469	3.068	4.026	6.065	7.981
Sch 80	1.500	1.939	2.323	2.900	3.826	5.761	7.625

Suggested Number of Pipe Holes												
PIPE SIZE	SCH 40						SCH 80					
	# 1/4" holes		#3/8" holes		# 1/2" holes		# 1/4" holes		#3/8" holes		# 1/2" holes	
	DIS	SUC	DIS	SUC	DIS	SUC	DIS	SUC	DIS	SUC	DIS	SUC
1.5"	50	63	19	24	11	14	36	45	16	20	9	12
2"	68	85	31	39	18	23	61	77	27	34	16	20
2.5"	98	123	44	55	25	32	87	109	39	49	22	28
3"	•	•	67	84	38	48	•	•	60	75	34	43
4"	•	•	116	145	65	85	•	•	104	130	59	74
6"	•	•	•	•	148	185	•	•	•	•	133	167
8"	•	•	•	•	255	319	•	•	•	•	233	292

**UNITED INDUSTRIES**  
 INCORPORATED  
 United Industries, Inc.  
 P.O. Box 58  
 Sterling, KS 67579  
 800-835-3272 • 620-278-3160  
 Fax 800-500-3115 • 620-278-3115  
 www.towerflo.com

Data presented here is the best available at the time of publication. United Industries and/or its representatives assume no liability for its use.

Form SWEEP:4/98

### STEP 1. UNPACK AND INSPECT THE FILTER

New Tower-Flo® Series TFH Filters should have been unwrapped and thoroughly inspected for freight damage upon receipt at your receiving dock, per the receiving stickers affixed to the filter's protective shrink-wrap. Freight damage issues must be addressed with the freight carrier when accepting delivery.

As you prepare to install your filter, confirm that you have:

- 1) the skid mounted filter system;
- 2) a cardboard box containing the pump pre-strainer and the filter vessel's air release valve;
- 3) a skid containing the correct number of bags of filter media (sand) for the size of your filter.

**TFH-18:** 8, 50 lb. bags    **TFH-24:** 14, 50 lb. bags    **TFH-30:** 18, 50 lb. bags    **TFH-36:** 14, 100 lb. bags

Re-inspect the filter system to check that all plumbing connections, especially union nuts, are hand tight and that there are no cracks or fractures in any of the external piping. Confirm that the direction of rotation switch on the electric valve actuator is in the "1" position.

### STEP 2. LOCATE FILTER

Place the TOWER-FLO® Filter System on a firm level surface. The TOWER-FLO® Filter does not need to be anchored, unless required by local code. Select a location close to the cooling tower to allow for convenience, accessibility and serviceability. If the filter is to operate year-round, exposure to winter conditions should be a consideration in your location decision.

#### WARNING

**If your TOWER-FLO® is to be installed BELOW the static water level of the tower sump:**

- 1) Install valves on the inlet, waste and outlet piping to permit removal or maintenance of filter system without draining the tower.
- 2) Install a balance leg with an air gap in the waste line (as shown below) to prevent gravity from draining the sump if a power loss should occur during a backwash cycle.
  - a) In lieu of a balance leg, you may install a normally closed solenoid valve in the waste line to prevent accidental draining of the tower; consult with TOWER-FLO® for proper electrical connections.

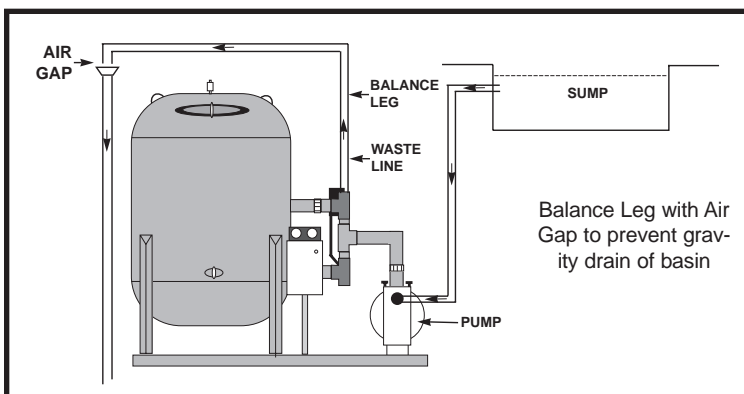

#### WARNING

**TOWER-FLO® Filters should never be installed on a dirty basin or reservoir. Installing the filter on a dirty basin will cause a nearly constant backwash condition. Always clean accumulated mud, silt, and debris from the bottom of the basin or reservoir BEFORE installation of the sidestream filter.**

#### WARNING

**TFH-18, -24, -30 filters are equipped with self priming pumps. The pump will prime on a straight vertical lift of up to 7 feet. However, when the need for self priming exists, horizontal pipe runs significantly reduce the ability of the pump to prime itself. When installing your filter in a self priming position, limit horizontal pipe runs to a *maximum of 18 inches*. If this limit is not practical for your installation, we recommend the use of a foot valve in the suction line in order to maintain self priming capability.**

### STEP 3. PLUMBING

- A) Fabricate and install sweeper piping system in water source with holes sized according to the Sweeper Pipe Sizing tables and formula found on page 10 of this manual; or if using TOWER-FLO® Sweeper-Eductor Nozzles, follow directions supplied with the nozzles. The sweeper piping system should be designed so that water returning from the filter sweeps particulate matter toward the suction line to the filter which is usually installed at or near the lowest point in the source water basin.
- B) Install the automatic air release valve on the nipple on the top of the vessel.
- C) Connect piping from water source to strainer inlet\*.
- D) Install return piping from filter's effluent (filtered water) valve outlet to water source\*.
- E) Install waste piping from backwash outlet valve to drain. The backwash sight glass shipped with the unit should be installed in the waste line (as shown below) in a position which allows convenient observation of backwash flow. Make certain the disposal point will handle the unit's stated backwash flow.
- G) To permit drainage of filter system for winterization, add drain valve at lowest point in side stream piping.

\*TOWER-FLO® recommends the installation of unions and/or valves in these three plumbing connections for ease of isolation or removal, should it become necessary for any reason.

NOTE: All plumbing connections should follow accepted plumbing procedures. Pipe joints should be sealed using teflon tapes without adhesive backings or with compounds suitable for use with PVC and ABS plastics.

Backwash Sight Glass

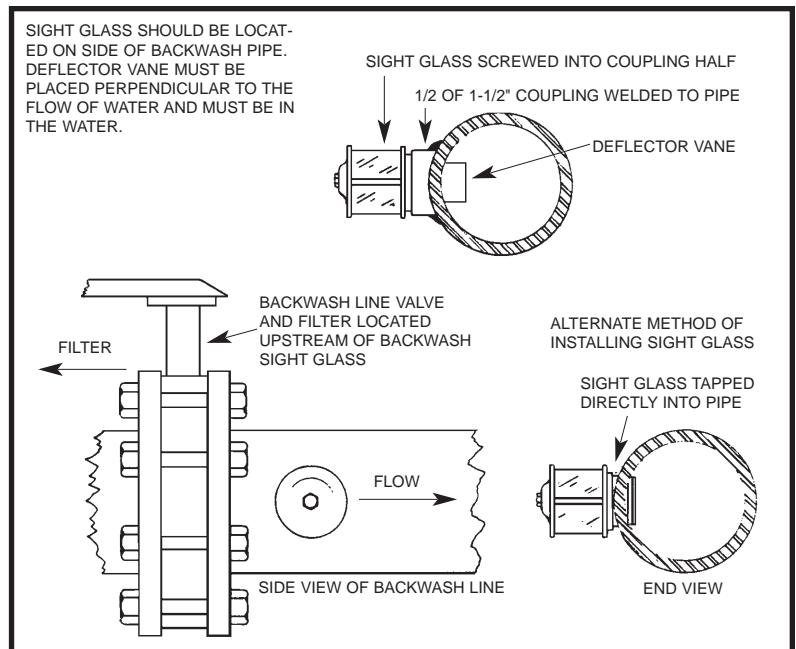

### STEP 4. ELECTRICAL

All TOWER-FLO® systems are pre-wired at the factory and require only field connections to power source. Proceed as follows:

- A) Check power supply wiring and related components for compatibility with system making sure local code requirements are met.
- B) Make all contacts according to the appropriate phase/voltage on the wiring schematic found on page 17 of this manual.

### STEP 4A. ANTI-SIPHON SOLENOID VALVE

Per the warning statement under STEP 2, you may choose to install a normally closed 24 VAC solenoid valve in the backwash line to waste designed to prevent accidental draining of condenser water should power loss occur to the control valves while in a backwash cycle. Such a valve is available, as optional equipment, from Tower-Flo.

Install the solenoid valve in the backwash line before it reaches the backwash sight tube or sight glass. Connect the solenoid valve to the filter control panel according to the schematic below.

#### UNIT CONTROL TERMINALS

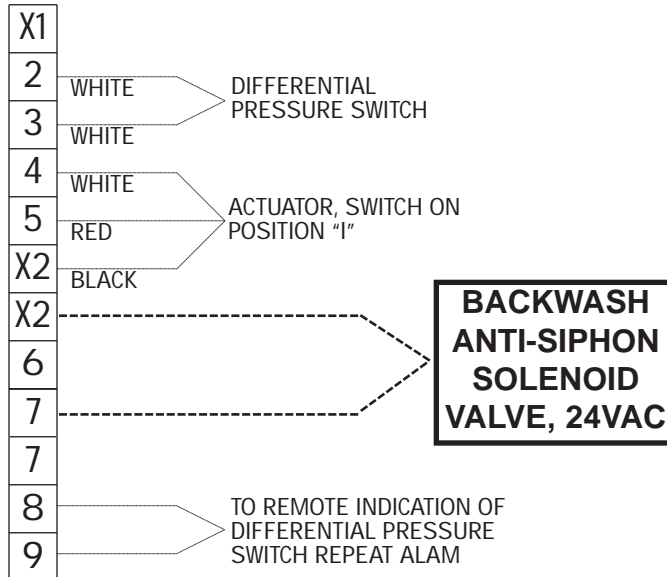



Series  
**TFH**

## Installation

### CAUTION

Extreme care must be taken while installing filter media to prevent damage to the lateral assembly.

### NOTE

1 Cubic Foot of .45-.55 mm sand media = 100 lbs

### STEP 5. FILTER MEDIA LOADING

- A) Open the air relief valve. This is a pressurized system which should never be opened without first bleeding off the pressure; make it a habit to always open the air relief valve even when the system is not pressurized!
- B) Remove the manway by loosening and removing the yoke and bolt assembly and the manway cover and gasket. Never attempt to open the manway while there is pressure in the filter.
  - 1) **TFH-18** filters have a flanged and gasketed top head. Remove the bolts, nuts and washers from the flange. Carefully lift or hoist the top head off of the filter vessel while assuring that the gasket is protected from damage.
- C) In **TFH-18, -24, -30** filters, inspect the underdrain laterals and ensure the slots in the laterals are facing downward. In **TFH-36** filters, the underdrain laterals are shipped loose for field installation in order to prevent damage to the laterals during shipment; install these laterals.
- D) Confirm that the vessel drain plug in the bottom of the vessel and the hand hole in the side of the vessel are in place and secured.
- E) Fill the tank with enough water to just cover underdrain laterals. This water will act as a buffer to protect laterals during media loading.
- F) With one person outside the vessel handing media in manageable quantities to another person inside the vessel, gently "float" media under and around the laterals until they are completely covered, then slowly add the rest of the media provided with the unit. See the specification table found in this manual for required amount.
- G) Replace and secure the manway cover or the flanged top head.

**UNITED**  
**INDUSTRIES**  
INCORPORATED

United Industries, Inc.  
P.O. Box 58  
Sterling, KS 67579  
800-835-3272 • 620-278-3160  
Fax 800-500-3115 • 620-278-3115  
www.towerflo.com

Form TFH-INSTAL4:7/08

Data presented here is the best available at the time of publication. United Industries and/or its representatives assume no liability for its use.

### WARNINGS

**THIS SYSTEM OPERATES UNDER PRESSURE AND SHOULD NEVER BE OPENED UNTIL THE PUMP IS SHUT OFF AND THE PRESSURE IS BLEED OFF THROUGH THE AIR RELIEF VALVE.**

Never operate filter at pressures over 100 psi. Such pressures indicate need for complete cleaning or a malfunction.

The filter system is designed to withstand water temperatures up to 120°F/49°C.

### START UP PROCEDURE

- A) Secure drain plugs in filter vessel, pump and pump strainer. Check tightening of set screws on pump shaft extension.
- B) Ensure suction, discharge (return) and waste line valves are open.
- C) Ensure that the black plastic thumb screw on the top of the automatic air release valve has been finger tightened and then loosened 2 turns for proper venting.
- D) If the filter is installed in a self-priming location (above source water level), remove strainer lid and fill strainer pot with water to facilitate priming of pump. Replace strainer lid according to instructions. If filter is in a flooded-suction location, Step B will cause the strainer to fill.
- E) Start the pump by turning both the on/off motor contactor switch and the disconnect switch on the face of the control panel to the on position. **There will be a 2 :30 minute time delay before the pump starts** (this delay will occur any time the system is restarted after a power interruption or disconnect). Allow up to 3 to 4 minutes for pump to prime. Pump is primed when strainer remains filled with water. If pump does not prime, repeat steps D, E, and F.
- F) Check proper pump rotation with arrow on pump housing by turning system on/off rapidly. If pump rotation is backwards, correct electrical connection.
- G) Close air relief valve when a steady stream of water flows from the valve into the clear plastic tubing -- this indicates that all air has been bled from the tank.
- H) Check system plumbing for leaks and repair.
- I) Your TOWER-FLO® is now in operation.
- J) NOTE FILTER'S INFLUENT PRESSURE READING AT START UP AND RECORD FOR FUTURE REFERENCE.

Start Up Date	_____
Influent Pressure	_____
Effluent Pressure	_____

- K) Allow system to filter for a brief period of time (approximately 5 minutes) then manually activate and observe a backwash cycle. This will rinse construction dirt and debris from the system.

**NOTE:** Small grains of sand may leave the filter during backwashing or may even appear at the return line when the filter is first started. This is characteristic of permanent media filters and should clear up after the first few backwash cycles. Should sand continue to appear at the return line over time, this is evidence that a collection lateral was cracked or broken during media loading and that lateral must be identified and replaced.

**THIS PAGE INTENTIONALLY BLANK**

### AUTOMATIC BACKWASH

All permanent media filter systems have a difference in pressure between fluid entering the filter (influent) and the fluid exiting the filter (effluent). This pressure drop, commonly referred to as differential pressure or  $\Delta P$ , will be approximately 3 psi when the filter media is clean. As system water passes through the media bed, particles in the water become trapped in the media. As the amount of trapped particles increases, so does the resistance to flow and the  $\Delta P$ . As the filter becomes increasingly loaded with trapped particles, the influent pressure will increase and the effluent pressure will decrease.

Your Tower-Flo® filter is equipped with an automatic backwash control system. Primary initiation of an automatic backwash is by the  $\Delta P$  switch, factory set to close on a 10 psi difference between the influent and effluent pressures. When this switch closes, a 30 second delay timer (T4) is initiated, and the switch must remain closed for the duration of that 30 second time delay before backwash is initiated. This prevents random pressure surges from initiating an unnecessary backwash.

Your Tower-Flo® filter's automatic backwash operation can also be initiated by two other means: 1) by depressing the manual backwash push button on the face of the control panel; or 2) by the 100-hour (field adjustable) "re-setting" backup timer (T5) which will force a backwash every 100 hours in the event that neither  $\Delta P$  nor Manual initiated backwash has occurred ( $\Delta P$  or manual initiation resets T5).

When any of these three backwash initiations occur, the programmable relay in the control panel will execute its pre-programmed timing sequence as described and time lined on the next page.

### ALARM

The control panel on your Tower-Flo® filter is equipped with a  $\Delta P$  switch repeat alarm (Timer T6). When an alarm condition occurs, the filter will automatically shut itself off, energize its alarm light, close the dry contacts provided for remote indication of alarm condition, and require manual attention at the filter's control panel to restart the filter system.

An alarm condition will occur:

- 1) If a  $\Delta P$  switch closure tries to initiate a second backwash within 15 minutes after a previous  $\Delta P$  switch initiated backwash.
- 2) If the  $\Delta P$  switch gets stuck in the closed position.

The Alarm condition is cleared by rotating the ON/OFF switch on the face of the control panel. When an alarm occurs, the operator must investigate the cause of the alarm. The  $\Delta P$  switch is normally open. Check continuity through the  $\Delta P$  switch across control terminals #2 and #3. If there is no continuity, condition #1 exists indicating there is most likely a problem with the media bed and media inspection must be conducted. If there is continuity, condition #2 exists and the  $\Delta P$  switch must be replaced.

### AUTOMATIC BACKWASH OPERATION

The series of events controlling automatic backwash are described below. The programmable relay follows these steps and timer identifications in its program of operation.

1. Differential pressure switch closes, initiates Timer T4, and remains closed for 30 seconds.
2. Timer T4 elapses, or the manual backwash push button is pressed, or Timer T5 elapses, which initiates Timer T1 and Timer T2. Timer T1 energizes the control relay to the valve actuators changing the valves to backwash position. Timer T2 interrupts the pump motor contactor stopping the pump while the valves rotate.
3. Timer T2 elapses, pump motor contactor is re-energized restarting the pump. Filter is now in backwash mode for 3 minute flow time.
4. Timer T1 elapses, Timer T3 initiated. T3 interrupts pump motor contactor stopping the pump. Timer T1 de-energizes the control relay to the valve actuators changing the valves back to filter position.
5. Timer T3 elapses, pump motor contactor is re-energized restarting the pump. Filter is now back in filter mode.

#### BACKWASH TIME LINE

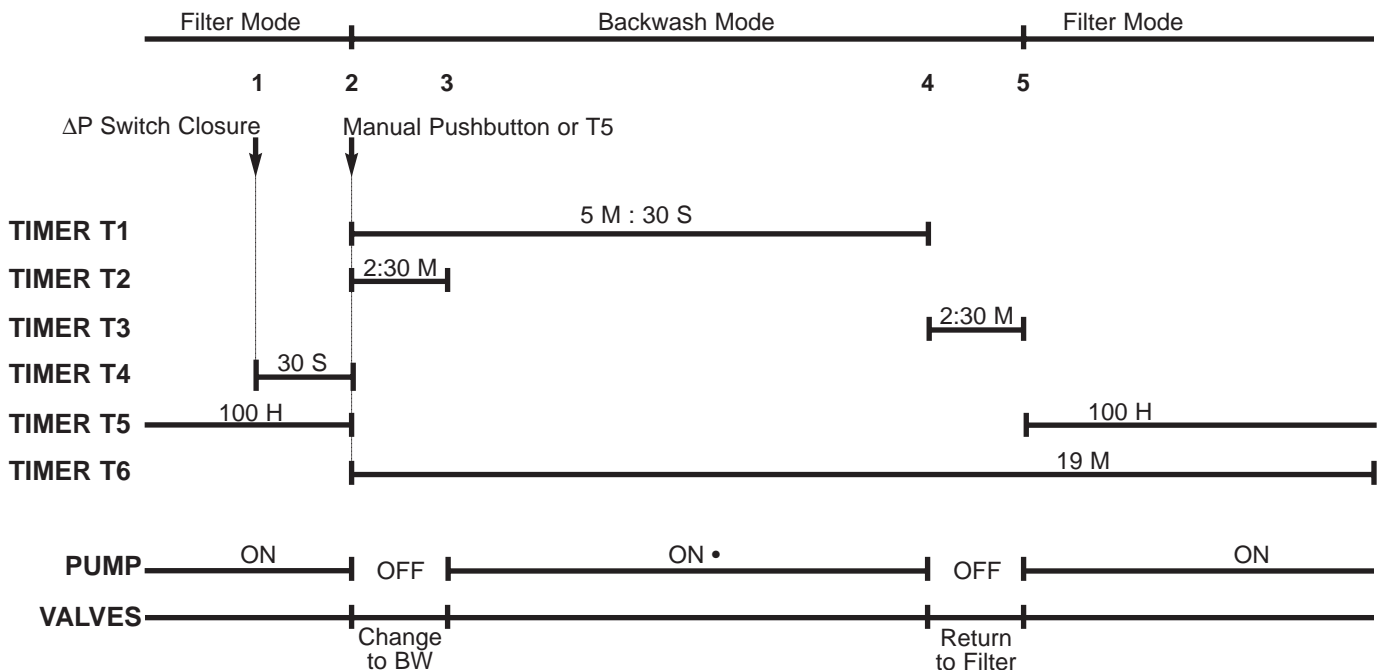

**NOTE:** Timers T5 and T6 are field adjustable through the PARAMETERS screen on the programmable relay. All other Timers are password protected and can only be changed with consultation from Tower-Flo®.

• **NOTE:** On filter systems equipped with optional fresh water backwash from municipal water supply, the pump is not energized for backwash. Factory setting of Timer T2 will be changed to 5:30.

The TOWER FLO® filtration system is virtually maintenance free. The following are guidelines to ensure proper performance and increase longevity of the system.

### WEEKLY

- 1) Check all plumbing connections for leakage.
- 2) Check all electrical connections and components for signs of malfunction or poor connection.
- 3) Visually inspect strainer basket through lid. If cleaning is necessary, turn system off, release pressure from filter vessel, remove strainer lid, clean basket, replace basket and lid following recommended safety procedures, and restart system following the Start Up Procedure.
- 4) Check pressure gauges for proper operation.

### MONTHLY

- 1) Place unit in "off" position.
- 2) Check automatic air release valve for proper operation. Slowly remove plug in top of valve; some pressure may remain in system if valve is dysfunctional.
- 3) Remove manway cover and inspect media bed. **See Media Inspection instructions on Page 32.**
- 4) Lubricate moving parts, i.e., linkage and handles.

### YEARLY

- 1) Inspect media bed for visible contamination or extraneous material. Media should be tested to a depth of 8" to 12".
- 2) Maintain proper level of media bed.



## Media Inspection

The filter sand provided with your Tower-Flo® filter is permanent media and should never require replacement. However, the media bed will function as a “concentrator” of both problem filtrates that resist removal by backwash action, as well as water treatment deficiencies. Regular monthly media bed inspections will keep your filter operating properly and can alert you to emerging water chemistry issues.

Media bed inspection requires accessing the media. Turn off the pump, close isolation valves in influent and effluent piping to the filter, open the tank drain, open the air relief valve, remove the manway cover, close the tank drain when the water level is low enough to expose the surface of the media bed.

Inspection is a three step process; smell, look, feel:

- Smell to see if the media smells clean. A “septic” smell would indicate the presence of live biological contaminants in the media bed and an issue with the biocide treatment. Sanitize the media bed with bleach.
- Look to see if the surface of the media bed is clean, smooth and flat. Remove any accumulation of fibrous materials (i.e., cottonwood tree seeds) or heavy materials that are not being removed by backwash action. The appearance of “ridges and valleys” on the surface of the media bed would indicate the beginning of hard spots down in the media bed (under the ridges) and an issue with water hardness control. Either remove the hardened media and replace with an equal volume of new sand or recondition media bed with a muriatic acid wash to dissolve calcium.
- Feel the sand at the surface to see if it is clean and loose. Probe the bed in several random places to a depth of 8 to 12 inches to see if it is clean, loose and free of evidence of foreign matter, mudballs, oilballs, or hard spots down in the media bed. If contamination is found, either remove the contaminated media and replace with an equal volume of new sand or recondition media bed with a muriatic acid wash to dissolve calcium or a low sudsing / low phosphate detergent to dissolve oilballs.

Resolution of problems revealed by your inspection requires the suggested remedies for the media bed (to treat the symptoms) as well as attention from those responsible for your water treatment / water chemistry program (to treat the problem).

After inspection, replace the manway cover, open isolation valves and restart your filter system according to the Start-Up Instructions.

**For SEASONAL SHUTDOWN of the TOWER-FLO® Filter System:**

1. **ELECTRICAL:** Disconnect electrical power.
2. **PUMP:** Drain liquid from the pump through the plug at bottom front section of volute. Addition of a good rust inhibitor into liquid end of the pump is recommended to prevent corrosion. Be sure the motor is kept dry and covered.
3. **VESSEL & VALVES:** Drain vessel and valves by removing the drain plug in the bottom of the vessel.
4. **GAUGES & DIFFERENTIAL PRESSURE SWITCH:** Disconnect influent and effluent pressure lines at facepiping and allow to drain, then reconnect.

**For YEAR-ROUND OPERATION of the TOWER-FLO® Filter System:**

In installations where freezing may occur, heat tracing of all slow moving or static lines, especially tubing to pressure gauges and differential pressure switch, is highly recommended. Use standard insulation and freeze protection methods for your region.

# TROUBLE SHOOTING

The trouble shooting pages are provided in order to give you the ability to locate and possibly remedy problems that may occur during normal operation of your TOWER-FLO® Water Filter System. If you are unable to solve the problem, please do not hesitate to contact us.

<b>PROBLEM</b>	<b>POSSIBLE CAUSE</b>	<b>SOLUTION</b>
PUMP STOPS	A Pump motor or circuit	A Check circuit breakers, wire connections (loose, broken or incorrect), thermal protector in motor starter tripped. Allow motor to cool, then try to restart <sup>1</sup>
WATER LEVEL DROPS IN BASIN	A Gravity draining of basin; filter installed below static water level of basin and power interrupted to pump during backwash	A Prevent gravity draining by following the warning instructions under Installation, Step 1., on page 7.
BACKWASHES TOO OFTEN OR CONSTANT BACKWASH	A Differential pressure switch adjusted too low; virtually constant closure B Differential pressure switch stuck closed C Backwash control circuit failure D High pressure drop through filter due to clogging	A Using bench air, check $\Delta P$ set at 10 psi. If at 10 psi, increase setting by two to three psi B Check switch for continuity with no pressure on system C Check circuit breakers, wire connections (loose, broken or incorrect), timers, and fuses, D Inspect filter bed for foreign material and contaminated or caked sand and remove from tank. Replace with same volume of clean, new silica sand
BACKWASHES TOO INFREQUENTLY OR NEVER	A Differential pressure switch adjusted too high for backwash initiation or B Differential pressure switch malfunction C No water flow D Low pressure drop through filter due to channeling	A Using bench air, check $\Delta P$ set at 10 psi. If at 10 psi, decrease setting by two to three psi B Check switch for continuity with no pressure on system C Check for 1. Loss of pump prime 2. Clogged strainer basket D Inspect filter bed for foreign material and contaminated or caked sand and remove from tank. Replace with same volume of clean, new silica sand
PUMP LOSES PRIME	A Strainer cover leaking B Water level too low C Suction line clogged or leaking D Horizontal run over 18" in suction line	A Check lid and O-ring for defects; tighten lid clamp B Add water C Inspect and repair as needed D See warning under Installation, Step 1., on page 7.
UNUSUAL NOISES	A Plumbing vibration B Bad motor bearings C Pump 1. Cavitation 2. Foreign objects in pump 3. Impeller out of adjustment	A Ensure all plumbing anchored properly B Repair or replace motor C 1. See A, B, and C directly above 2. Check volute and impeller 3. Adjust impeller by loosening the three set screws in the shaft extension and repositioning the impeller to center of pump volute
SAND BEING DRIVEN TO TOWER	A Cracked or broken lateral(s)	A Replace cracked or broken laterals

<sup>1</sup>If motor re-starts after cooling, check amperage draw at the motor and compare to Full Load Amp Draw (FLA) as noted in Your Filter's Specifications on page 4. If amp draw is above noted FLA draw, reduce flow on discharge side of pump.