

TFH-18 DIMENSIONS

| | |
|---------------------------------------|--------|
| Influent Connection | 2" FPT |
| Effluent Connection | 2" FPT |
| Backwash Connection | 2" FPT |
| A Vessel OD | 18" |
| a Flange OD | 24" |
| B Overall Length | 41" |
| b Base Length | 38" |
| C Overall Width | 25" |
| c Base Width | 16.75" |
| D Vessel to Influent ϕ | 19" |
| E Grade to Influent ϕ | 12" |
| F Grade to Effluent Valve ϕ | 24" |
| G Eff Valve ϕ to BW Valve ϕ | 15" |
| H Overall Height | 61.5" |

NOTE: All dimensions are approximate and must be field verified.

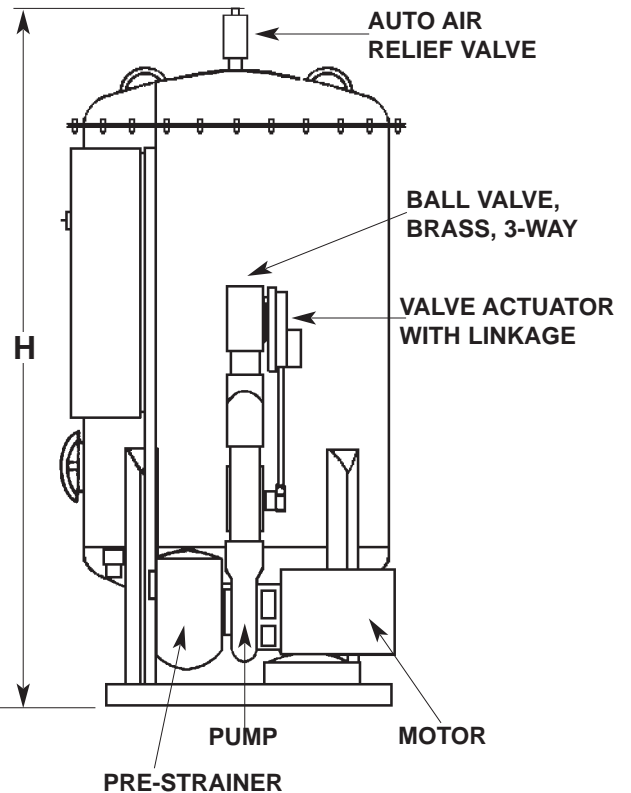

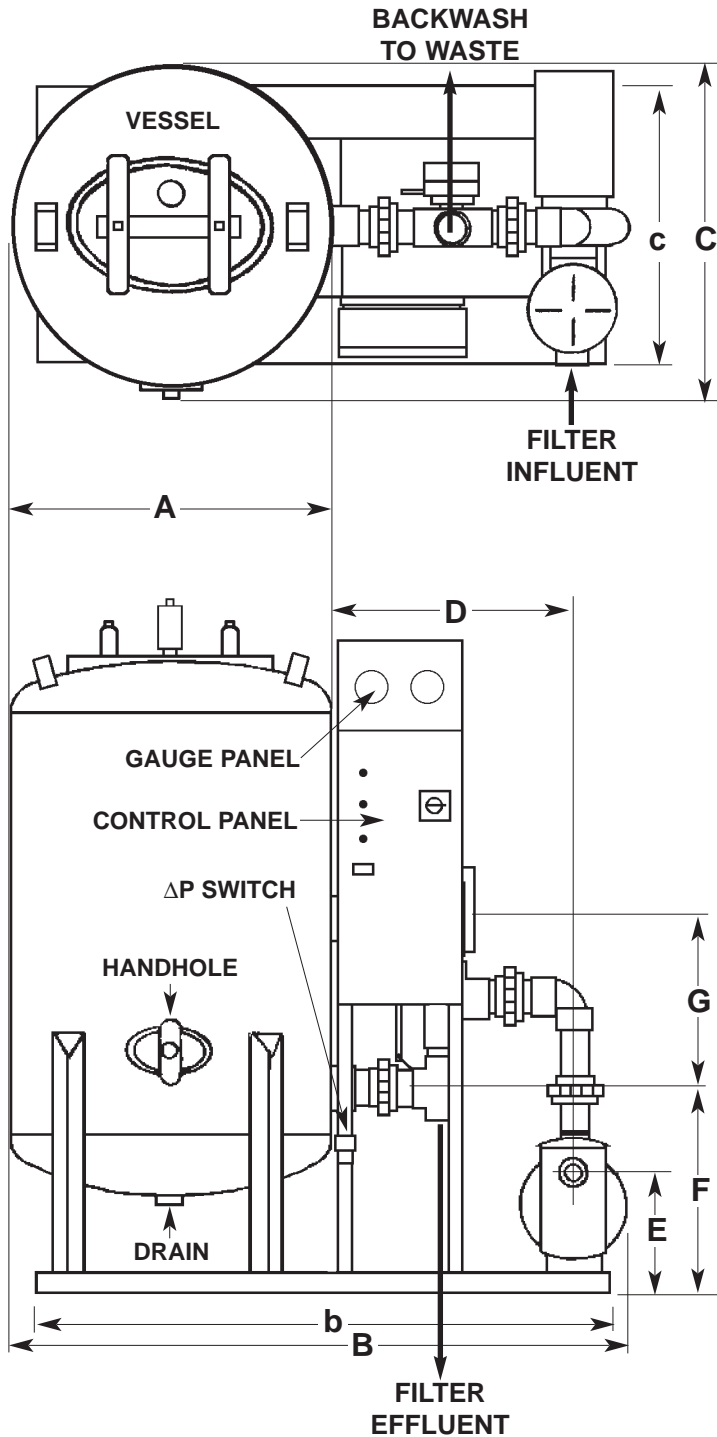

| DIMENSIONS | 24 | 30 |
|---|--------|-------|
| Influent Connection | 2" FPT | |
| Effluent Connection | 2" FPT | |
| Backwash Connection | 2" FPT | |
| A Vessel OD | 24" | 30" |
| B Overall Length | 49" | 55" |
| b Base Length | 46" | 52" |
| C Overall Width | 28" | 34" |
| c Base Width | 22" | 26" |
| D Vessel to Influent ϕ | 19" | 19" |
| E Grade to Influent ϕ | 12" | 12" |
| F Grade to Effluent Valve ϕ | 20.5" | 20.5" |
| G Eff Valve ϕ to BW Valve ϕ | 15" | 15" |
| H Overall Height | 59" | 65" |

NOTE: All dimensions are approximate and must be field verified.

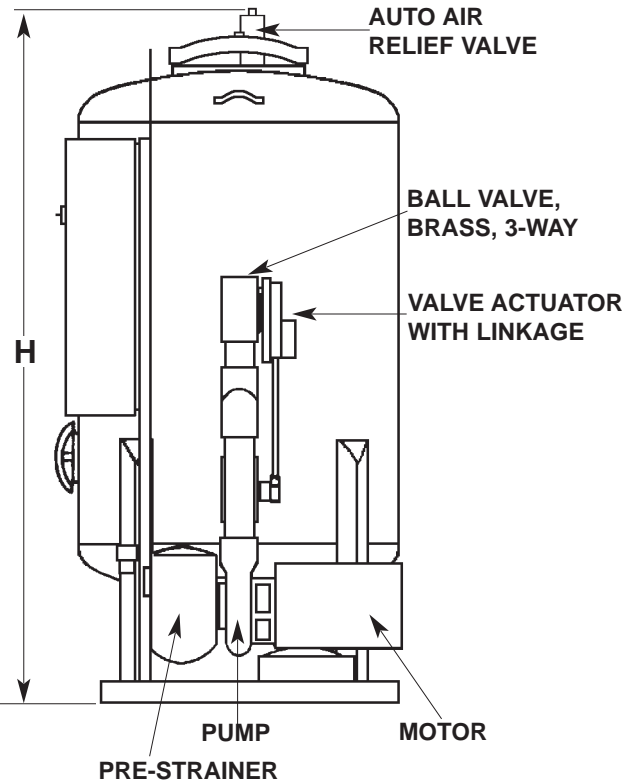

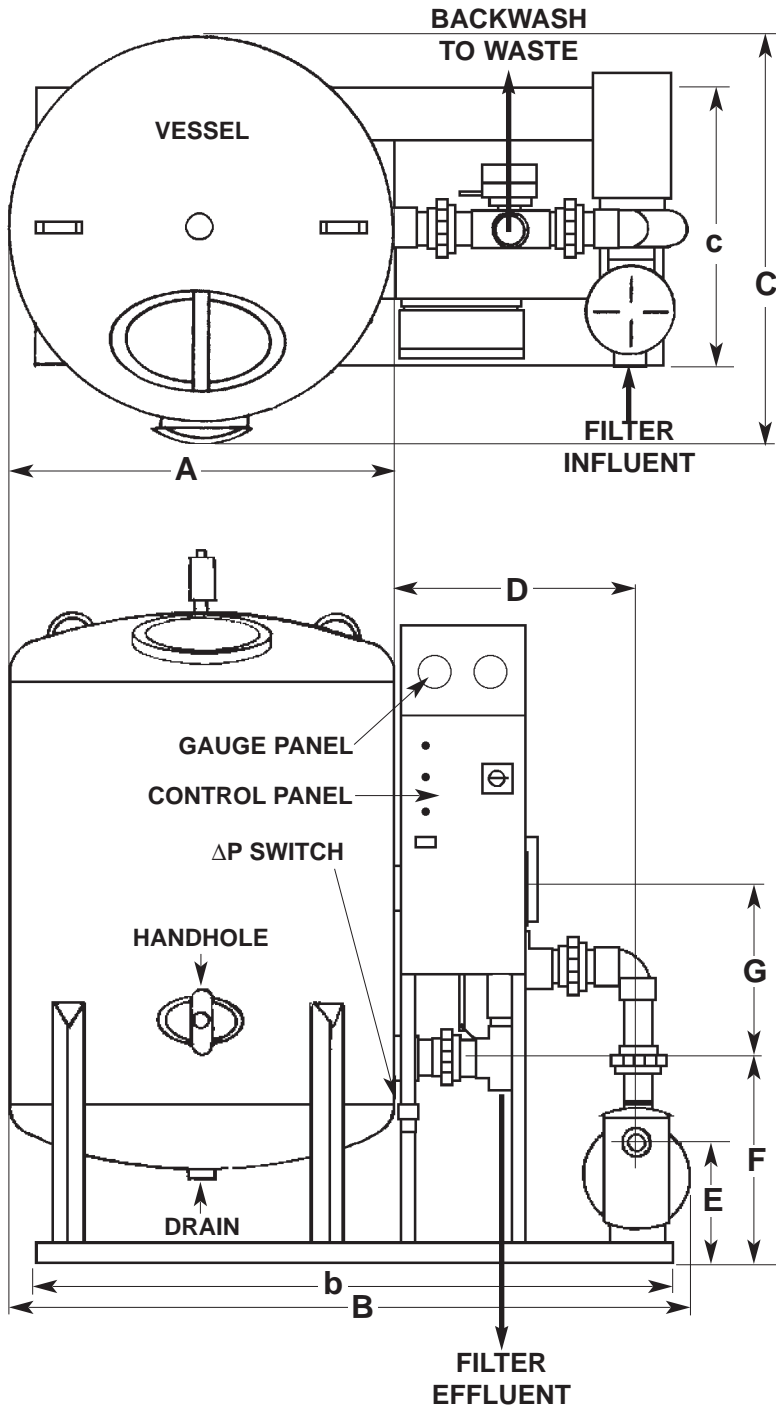

TFH-36 DIMENSIONS

| | |
|---------------------------------------|--------------|
| Influent Connection | 2.5" Flanged |
| Effluent Connection | 2" FPT |
| Backwash Connection | 2" FPT |
| A Vessel OD | 36" |
| B Overall Length | 62" |
| b Base Length | 58" |
| C Overall Width | 40" |
| c Base Width | 30" |
| D Vessel to Influent ϕ | 20.5" |
| E Grade to Influent ϕ | 13" |
| F Grade to Effluent Valve ϕ | 19.5" |
| G Eff Valve ϕ to BW Valve ϕ | 15" |
| H Overall Height | 61" |

NOTE: All dimensions are approximate and must be field verified.

