



TECHNICAL MANUAL

for
Series

TFB

Water Filter Systems



Complete information for

Engineering, Installation, Operation & Maintenance

of Tower-Flo® Series TFB Water Filter Systems

**UNITED
INDUSTRIES**

INCORPORATED

TOWER-FLO® Division

United Industries, Inc.

P. O. Box 58

Sterling, KS 67579

800-835-3272 • 620-278-3160

Fax 800-500-3115 • 620-278-3115

www.towerflo.com

Form ID	Current	Description	Page
TFB-INDEX	2/10	Index	2
		Warranty	3
		Warranty Registration	4
TFB-DESC	2/10	System Description	5
TFB-PSPC	5/10	Project Specifications	6-8
		Blank	9
TFB-COMP	12/07	Components	10
TFB-DIM	12/07	Dimensions	11
TFB-FLOW	11/07	Flow Diagrams	12
FAILSAFE	2/10	Backwash Fail/Safe Feature	13
TFB-PTS1	12/09	Parts, Page 1	14
TFB-PTS2	12/09	Parts, Page 2	15
TFB-ELEC-EZ	4/10	Electrical Schematic-Three Phase EZ Control Panel	16
TFB-PTS-CNTL	12/09	Parts, Controls	17
TFB-FWBW-M	12/07	Option: Fresh Water Backwash from Municipal Supply	18
TFB-FWBW-S	12/07	Option: Fresh Water Backwash from Static Supply, Pump Assisted	19
INISS	4/98	Installation Issues	20
SWEEP	4/98	Basin Sweeper Piping	21
TFB-INSTAL1	2/10	Installation Instructions, Page 1	22
TFB-INSTAL2	2/10	Installation Instructions, Page 2	23
TFB-INSTAL3	2/10	Installation Instructions, Page 3	24
TFB-INSTAL4	2/10	Installation Instructions, Page 4	25
TFB-START1	2/10	Start Up, Page 1	26
TFB-START2	2/10	Start Up, Page 2	27
TFB-OPER1	10/04	Operating Instructions, Page 1	28
TFB-OPER2	10/04	Operating Instructions, Page 2	29
TFB-MNTN	2/10	Maintenance instructions	30
TFB-MEDINSP	10/01	Media Inspection Instructions	31
TFB-WINT	6/99	Winterization Instructions	32

Filter Model Number _____ Filter Serial Number _____

Total Filter Surface Area _____ Filtration Rate: Maximum **20** GPM/ft² of Filter Surface Area

Required clearance for service and maintenance: Vertical height _____ Horizontal width _____

Filter Flow Rate GPM: Filtration _____ Backwash _____ Maximum Working Pressure _____

Warrant only to _____,

the original retail purchaser, that the products which are manufactured by United Industries, Inc. are free from defects in material and/or workmanship for a period of twelve months from the date of documented installation or, in absence of documented installation date, 12 months from the date of factory shipment. The warranty registration card in this manual **MUST** be completed and returned to United Industries, Inc. in order to establish the date of installation and extend the warranty period. If, within the period provided by this warranty, any such product shall prove defective, it shall be either repaired or replaced.

For repair/replacement, the original retail purchaser shall first contact the installing dealer, as soon as possible after discovery of the defect, but in all events prior to the expiration date of the warranty. Upon notification by the dealer, United Industries, Inc., 202 East Cleveland, Sterling, Kansas 67579 will advise the purchaser of the address to which the defective item may be shipped. The serial number and the date of purchase of the item must be included. Regular UPS cost for shipping replacement part(s) to the customer will be borne by United Industries, Inc.; shipping other than regular service will be at the customer's expense. Customer is responsible for cost of shipping defective part(s) back to United Industries.

If an installing dealer was not involved, then the customer should contact United Industries, Inc.

EXCLUSIONS

1. This warranty shall not apply to any failures resulting from: negligence, abuse, misuse, misapplication, improper installation, alteration or modification, chemical corrosion, or improper maintenance.
2. Any items manufactured by other companies and used by United Industries in its products may carry warranties by the original manufacturers.
3. United Industries is not liable for incidental or consequential damages, loss of time, inconvenience, incidental expenses, labor or material charges in connection with removal or replacement of the equipment.

United Industries is not responsible for any implied warranties or representations by others, and the foregoing warranty is exclusive and in lieu of all warranties provided herein. Some states do not allow the exclusion or limitation of incidental or consequential damages, so the above limitation or exclusion may not apply to you. This warranty gives you specific legal rights, and you may also have other rights which vary from state to state.

IMPORTANT

Read and fully understand the WARNING labels on the equipment. **DO NOT OPERATE** this unit if any unsafe conditions exist.

WARNING

THIS FILTER SYSTEM OPERATES UNDER PRESSURE. DO NOT OPEN WHILE PUMP IS RUNNING AND/OR UNTIL ALL PRESSURE IS RELEASED THROUGH AIR RELIEF VALVE. SECURELY TIGHTEN VESSEL AND STRAINER CLAMP ASSEMBLIES ACCORDING TO MANUFACTURER'S INSTRUCTIONS. RAISE PRESSURE SLOWLY. DO NOT EXCEED THE MAXIMUM WORKING PRESSURE OF THE VESSEL.

DANGER! EXTREME CARE MUST BE TAKEN DURING PRESSURE TESTS. FAILURE TO FOLLOW THESE INSTRUCTIONS EXPLICITLY CAN RESULT IN PERSONAL INJURY.

Continuous sidestream filtration for removal of suspended solids is one, very important portion of a total water quality management program, which should also include the services of competent water treatment professionals for proper control of water hardness, pH, and biological contaminants.



WARRANTY REGISTRATION

EXTEND YOUR WARRANTY!

**COMPLETE AND RETURN THIS WARRANTY REGISTRATION CARD WITHIN 10 DAYS OF
INSTALLING YOUR FILTER TO EXTEND YOUR WARRANTY PERIOD!**

Congratulations on your selection of a TOWER-FLO® Water Filter System by United Industries, Inc.!

Your TOWER-FLO® Filter is designed and manufactured for years of virtually maintenance-free service. As with any mechanical equipment, however, components can and do fail. If you ever have a problem, Tower-Flo® is committed to supporting you and helping you get your filter back in operation as soon as possible, whether it remains under warranty or not.

Your TOWER-FLO® Filter is covered by a limited warranty as stated on the previous page. This warranty is for 12 months from the date of documented installation or, in the absence of documented installation date, 12 months from the date of factory shipment. **In order to receive the maximum warranty benefit, you must complete and return the Warranty Registration Card below within 10 days of installation to register your warranty and ensure your warranty rights.** Failure to complete and return this Warranty Registration Card will result in your warranty being limited to 12 months from the date of factory shipment.

For Your Records

Date of Installation _____ Date Warranty Registration Card Mailed _____

Complete the card below. Cut along dotted line. Return to:

Warranty Registration
Tower-Flo® Filter Division
United Industries, Inc.
P. O. Box 58
Sterling, KS 67579



Manufacturer's Warranty Registration

Filter Serial Number: _____

Purchased by: Company: _____

Address: _____

City: _____ State: _____ Zip: _____

Contact Person: _____ Phone: _____

Date of Installation: _____



Series
TFB

System Description

The information below provides a general description of the main components of Series TFB filter systems. Details of standard, optional, and additional components are found in the **Project Specifications** document, on the following pages.

MAIN COMPONENT DESCRIPTION

A. HIGH RATE SAND FILTER VESSEL

This permanent media, high-rate sand filter is a vertical pressure vessel constructed of epoxy lined carbon steel designed for a maximum working pressure of 50 psi with a special influent baffle in the top of the tank, a bed of filter sand supported by gravel and rock, and a mechanical underdrain system which collects the filtered water and directs it to the return piping system. The filter operates under pressure. When closed properly and operated without air in the water system, this filter will operate safely. The system is equipped with an automatic air relief valve and 0-60 psi influent and effluent pressure gauges mounted in a common panel.

B. VALVE ASSEMBLY

The valves are drilled lug style butterfly, cast iron body, 416 stainless steel stem, EPDM seat, nylon coated disc, joined by adjustable linkage to a single, dual acting pneumatic actuator, and an air filter/regulator to receive compressed air from an outside source. Air demand is less than 1.0 SCFM per actuation at 80 PSI.

C. CONTROL PANEL

The control panel provides all controls for automatic backwash operation. The standard control panel is UL® and cUL® Labeled in a NEMA 4X corrosion resistant fiberglass enclosure. Backwash is initiated by: 1) differential pressure switch (external to the enclosure); 2) manual backwash pushbutton on face of control panel; or, 3) 100 hour "re-setting" timer (ΔP switch closure or manual initiation resets timer) for backup initiation. The sequence of the operation is described under the Operation section of this manual. The controls automatically stop the system's pump whenever valves are to be shifted which prevents water hammer, pipe flexing, and the risk of damage to collection laterals in the vessel.

D. PUMP

The standard **non**-self-priming pump has a machined cast iron volute, bronze impeller, horizontal flooded section, and is close coupled to an TEFC motor.

E. MOTOR

The totally enclosed motor with its external fan-cooled construction allows for operation in noncombustible, dusty, dirty atmospheres. It is enclosed in a class 30 cast iron case, on a NEMA jm frame, rated at a service factor of 1.15 at 40° over ambient, UL and CSA listed.

F. STRAINER

The pump suction strainer has a cast iron body, stainless steel basket, cast iron cover with gasket, held in place with a yoke and bolt clamp.

G. MEDIA

Filter media is shipped with the unit for field installation. It is quartzite or silica in nature, hard, not smooth, and has a uniformity coefficient of 1.7 with effective sizes as follows: Sand .45 - .55 mm; Gravel 1/8" - 1/4"; and Rock 1/4" - 1/2". Sand shall contain no more than 5% flat particles, or more than 1% clay, loam dust, or other foreign material. Gravel and Rock shall contain no more than 2% flat particles. At the discretion of the owner or installer, the bottom of the vessel below the collection laterals shall be filled with either rock or concrete (Fill). Concrete will increase vessel stability, however, concrete is not supplied by Tower-Flo®.



United Industries, Inc.
P.O. Box 58
Sterling, KS 67579
800-835-3272 • 620-278-3160
Fax 800-500-3115 • 620-278-3115
www.towerflo.com

Form TFB-DESC:2/10

Data presented here is the best available at the time of publication. United Industries and/or its representatives assume no liability for its use.



Series
TFB

Project Specifications

1,005 GPM MAX FLOW RATE 50 PSI WORKING PRESSURE

Model Number	Base Dimensions	HP	Max GPM	TDH Ft.	Amp Draw		Area SqFt	Media Volume CuFt			Operating Weight in Lbs	
					230V	460V		Sand	Gravel	Rock (Fill)		
TFB-36	34" X 84"	3	141	53	8.3	4.2	7.0	14	-	-	-	4300
TFB-42	34" X 88"	3	192	40	8.3	4.2	9.62	18	3	5	3	6024
TFB-48	38" X 94"	5	250	40	13.0	6.5	12.57	23	4	12	5	8096
TFB-54	42" X 102"	5	318	40	13.0	6.5	15.90	29	4	14	7	9905
TFB-60	46" X 108"	7.5	393	40	19.3	9.7	19.63	35	5	17	10	11840
TFB-66	54" X 114"	7.5	475	40	19.3	9.7	23.76	42	6	22	14	14595
TFB-72	55" X 120"	10	565	40	25.4	12.7	28.27	52	8	24	19	17118
TFB-78	59" X 128"	10	664	40	25.4	12.7	33.18	59	9	30	23	19857
TFB-84	64" X 134"	15	770	40	37.6	18.8	38.48	68	10	34	28	22927
TFB-90	68" X 145"	15	884	40	37.6	18.8	44.18	80	12	40	33	28643
TFB-96	72" X 152"	15	1005	40	37.6	18.8	50.26	96	14	44	39	32305

TOWER-FLO® Series TFB self-contained filter plants shall consist of the following major components: base, pump, motor, strainer, facepiping, valves, controls, and filter vessel. The system shall be shipped as a complete factory assembled and tested unit. Filter media shall be shipped with the unit for field installation.

Project: _____ Date: _____

The TOWER-FLO® Series TFB Model being specified for this project is a TFB-_____ with a maximum filter rate of _____ GPM. _____ unit(s) is(are) specified and each unit shall be equipped with the following components:

COMPONENT SPECIFICATION

BASE _____ **Standard 36-78:** Structural steel channel, primed and coated (same as vessel coatings).
 _____ **Standard 84-96:** Structural steel I-beam, primed and coated (same as vessel coatings).
 _____ **Option 36-78:** Structural steel I-beam, primed and coated (same as vessel coatings).

PUMP _____ **Standard:** Non self-priming; machined cast iron volute, bronze impeller, horizontal flooded suction, close coupled to a TEFC motor; and capable of _____ GPM at _____ feet TDH.
 _____ **Option 36-72:** Self-priming; close-coupled to motor; specified as follows: _____ and capable of _____ GPM at _____ feet TDH.
 _____ **Option 78-96:** Self-priming; long-coupled to motor requiring field alignment by others; specified as follows: _____ and capable of _____ GPM at _____ feet TDH.

MOTOR _____ **Standard:** Three phase; 60 Hz; TEFC; class 30 cast iron case; NEMA jm frame; rated at a service factor of 1.15 at 40°C over ambient; _____ HP; UL and CSA listed; at the following VAC, phase and Hz: _____.
 _____ **Option:** 575V.
 _____ **Option:** Premium Efficiency motor, _____%

STRAINER _____ **Standard:** _____", cast iron body; stainless steel basket; cast iron cover with gasket, held in place with a yoke and bolt clamp; with necessary eccentric and concentric reducers for pump connections and gaskets, bolts and nuts necessary for complete factory assembly.



Series
TFB

Project Specifications

FACEPIPING ___ **Standard:** Class 1, 150 lb. ductile iron flanged fittings; synthetic rubber gaskets; zinc plated nuts and bolts; backwash sight glass; 0-60 psi influent and effluent pressure gauges in common panel; adjustable mechanical valve linkage; dual-acting pneumatic cylinder (80 psi air pressure) with 4-way air solenoid valve, and an air filter/regulator to receive compressed air from an outside source (air demand is less than 1.0 SCFM per actuation at 80 PSI).

___ **Option:** Fresh water backwash from municipal water supply; includes addition of: 3-way butterfly valve with pneumatic actuator after pump discharge; controls modified to stop pump during backwash; flow control valve for field installation; end-user responsible for the addition of pressure regulator (maximum 30 psi) and/or backflow preventer, if required.

___ **Option:** Fresh water backwash from static water supply using pump to assist, includes addition of 3-way butterfly valve in front of pump suction.

___ **Option:** Flow control valve (one valve which controls both filter and backwash flow rate); recommended on slipstream installations under pressure.

___ **Option:** Provide a 3/4 HP air compressor with 3 gallon reservoir. Air compressor requires separate 120 VAC power supply and is not suitable for outdoor installation: ___ factory mounted on filter base, power by others; ___ factory mounted on filter base, power through filter control panel and as indicated under controls option; ___ boxed for field location and installation by others.

VALVES ___ **Standard:** ___", cast iron bodied, drilled lug style, butterfly valves, with 416 stainless steel stem, EPDM seat, nylon coated disc.

___ **Option:** Electric actuation. (NOTE: Eliminates pneumatic actuation fail/safe feature and requires additional means, by others, of backwash syphon break in flooded suction installations.)

CONTROLS ___ **Standard, three phase or single phase, Automatic backwash operation:** UL® and cUL® Labeled control panel with: NEMA 4X corrosion resistant fiberglass enclosure; motor starter with thermal overload and short circuit protection; fuseless branch and control circuit protection; transformer to convert primary supply to 24 and 120 VAC control power; through-the-door power disconnect; programmable relay with adjustable timing controls for backwash steps; program protected internally against power failure; 30-second time delay in delta P switch circuit; 1-100 hour "re-setting" timer (ΔP switch closure or manual initiation resets timer) for backup backwash initiation; ΔP repeat closure shut-off and alarm; manual ON/OFF switch; manual backwash initiation switch; backwash counter; and differential pressure switch (external to the controls enclosure) for primary backwash initiation.

___ **Option:** Backwash lockout between/among ___ units; to prevent simultaneous backwash of multiple filter units; 0-60 minute adjustable lockout time delay program; field connection between/among control panels by others.

___ **Option:** Contacts for connection to BMS, additional specifications required from owner.
___ remote indication of common alarm.
___ remote indication of backwash in operation.
___ remote control of pump on/off with HOA switch.
___ other (be specific) _____.

___ **Option:** Air compressor power supply included in filter control panel.

___ **Option:** Manual backwash; ___ single-phase; ___ three-phase.

VESSEL ___ **Standard:** ___" diameter, carbon steel; interior tank coating of 15-18 mil two-part epoxy after near-white sandblast; exterior tank primer of two-part epoxy after sandblast cleaning; exterior finish coating of two-part industrial and marine grade polyurethane; Schedule 80 PVC and polypropylene internals; 14" X 18" access manway; 4" X 6" handhole; 50 psi working pressure; fitted with tank drain, influent and effluent pressure taps, automatic and manual air relief valves. Maximum flow rate _____ GPM at 20 GPM per square foot filter surface area.

___ **Option:** working pressure to ___ psi.

___ **Option:** Uniflex™ heat set PVC interior vessel lining, 60-90 mil finish thickness, 15 year limited vessel warranty.

___ **Option:** _____.



Series
TFB

Project Specifications

INTERNALS ___ **Standard:** Sch. 80 PVC pipe. Influent terminates into a perforated distribution header. Effluent header fitted with 1-1/2" Sch. 80 PVC laterals, machine slotted both sides with .016" slots at 10 slots to the inch, maximum lateral spacing of 3-3/4" O.C., fabricated for minimum **field installation**. Total open area of laterals no less than 6 times the open area of the effluent header and water velocity through the laterals less than 1 foot per second. Influent and effluent header supported internally and secured with stainless steel bands.
___ **Option:** Type 304 stainless steel header & lateral; lateral spacing and open area design varies from above standard specifications.

MEDIA ___ **Standard:** Quartzite or silica in nature, hard, not smooth, uniformity coefficient of 1.7, with effective sizes as follows: Sand .45 - .55 mm; Gravel 1/8" - 1/4"; and Rock 1/4" - 1/2". Sand shall contain no more than 5% flat particles, or more than 1% clay, loam dust, or other foreign material. Gravel and Rock shall contain no more than 2% flat particles. At the discretion of the owner or installer, the bottom of the vessel below the collection laterals shall be filled with either rock or concrete (Fill). Concrete will increase vessel stability, however, concrete is not supplied by Tower-Flo®.

COMMON ADDITIONAL EQUIPMENT:

NOZZLES ___ **Sweeper-Eductor Nozzle**, 1/4" MPT, ABS plastic, quantity of ___.

HOLDERS ___ **Clip-On Nozzle Holder**, quantity of ___; for ___ 1-1/4"; ___ 1-1/2"; or ___ 2" PVC pipe.

SURGE TANK ___ **Polyethylene tank** for backwash surge capture and gravity release to closest drain: ___ gallon capacity, ___" diameter x ___" high, with a ___" diameter lid in top head and a 2" FPT drain bulkhead fitting.
___ Additional ___" bulkhead fitting for inlet from filter (2", 3", or 4"), field installed by others; ___ 2", 2-way, manual ball valve, ___ Sch 40 PVC, ___ Sch 80 PVC, ___ brass, for field installation by others on drain piping from tank for isolation and/or throttling.

LIQUID LEVEL ___ **Liquid level control assembly** for backwash surge tank to interrupt filter pump if/when surge tank nears capacity. Includes: ITT McDonnell-Miller 750B liquid level controller mounted in separate NEMA 3R enclosure requiring separate 120 V power supply factory mounted on filter's control panel bracket (unless otherwise specified); sensor; 3 trimmable probes (L, H, and Ground); field wiring from sensor to LLC enclosure by others. Also includes additional contacts for remote pump on/off in filter control panel.
___ **Option:** Liquid level control column assembly; 2" Sch 80 piping assembly mounted on side of poly tank to isolate liquid level probes from turbulence in poly tank.

NOTE: Backwash flow rate, irrespective of water source, must be no less than 75% and no greater than 100% of the vessel's designed maximum gpm. Backwash duration is factory preset at 3 minutes and is field adjustable.



United Industries, Inc.
P.O. Box 58
Sterling, KS 67579
800-835-3272 • 620-278-3160
Fax 800-500-3115 • 620-278-3115
www.towerflo.com

Member
Cooling Tower Institute
NSF Listed

Form TFB-PSPEC:5/10-P3

Data presented here is the best available at the time of publication. United Industries and/or its representatives assume no liability for its use.

This page intentionally blank

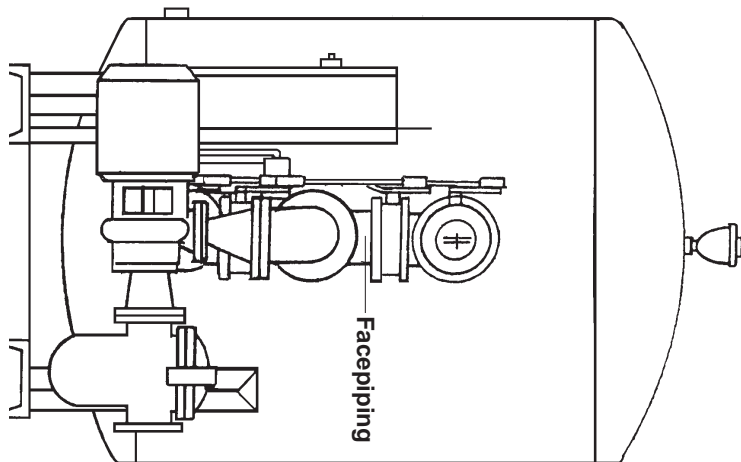
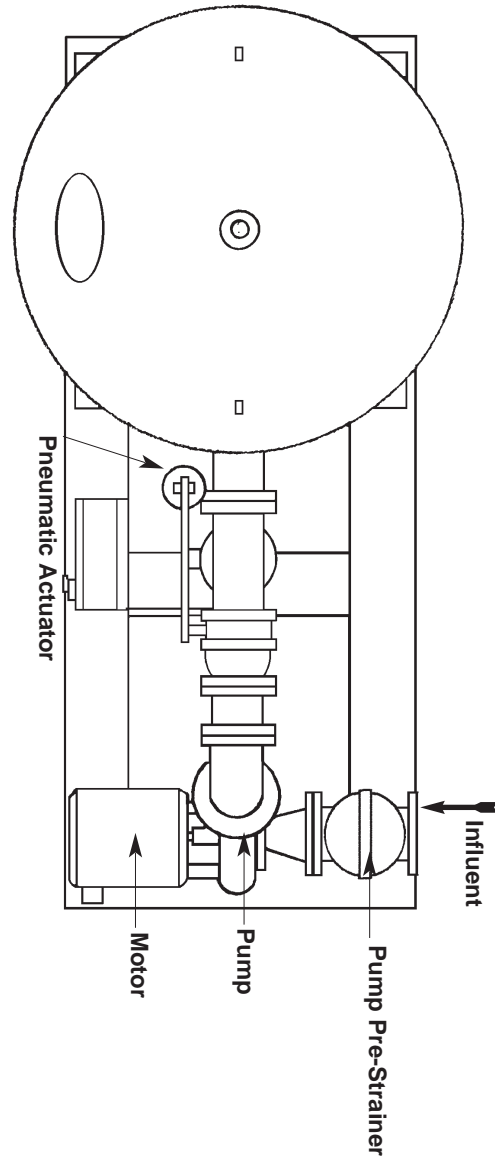
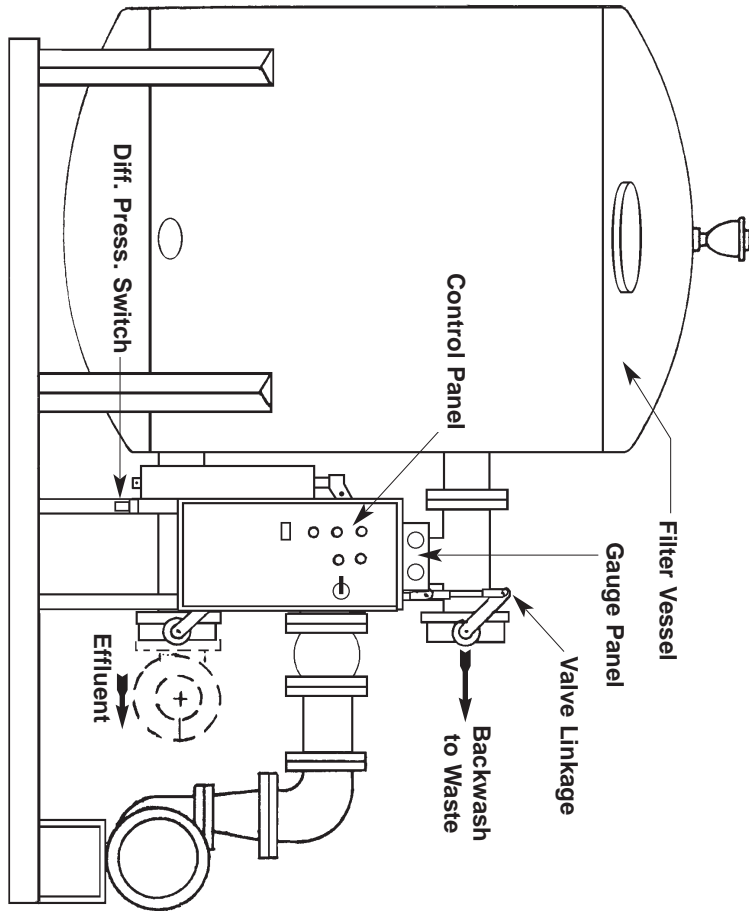

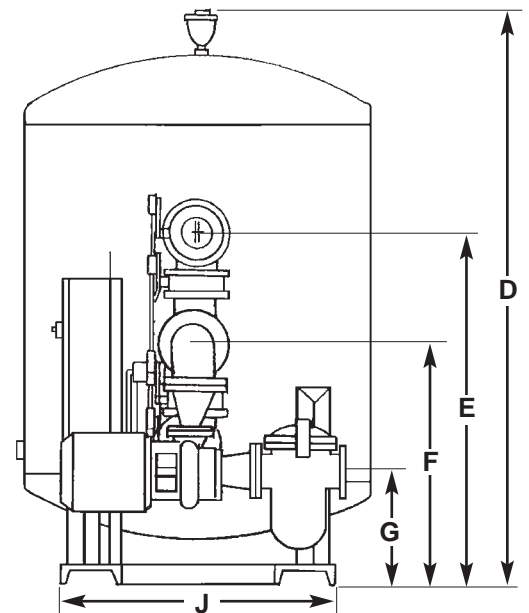
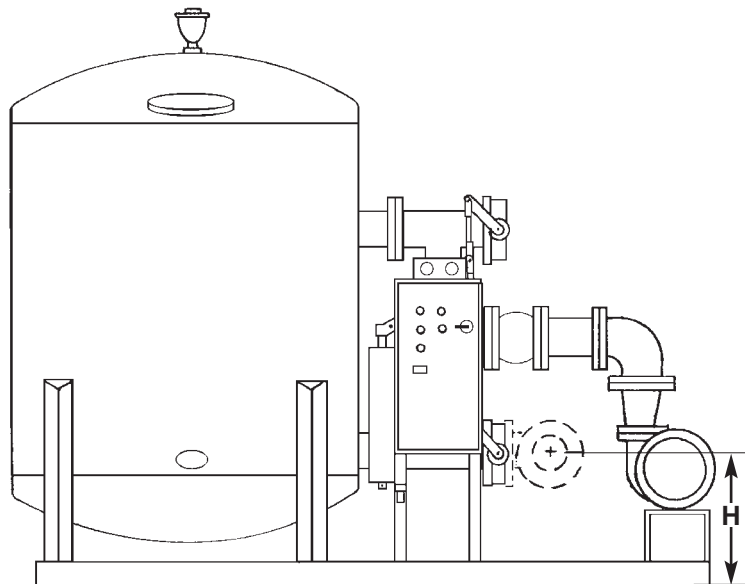
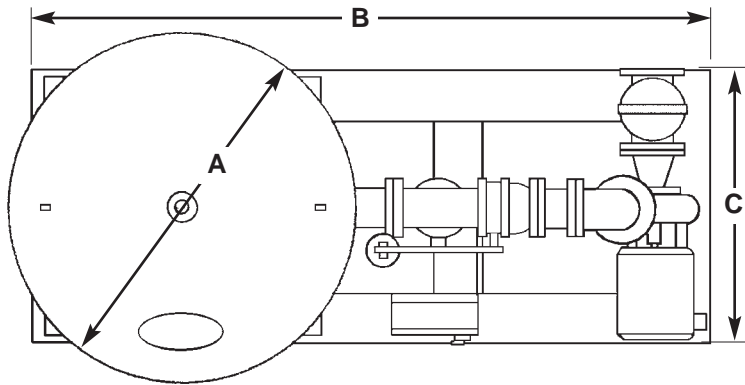

Dimensions

Catalog Number	Model TFB-	Max GPM	Face Pipe	Suction Connection	A	B	C	D	E	F	G	H	J
P263360B	36	141	3"	3"	36	80	28	72	47	34	9.5	21	32
P263420	42	192	3"	3"	42	88	39	74	43	30	11	17	34
P263480	48	250	4"	4"	48	94	41	76	49	34	12.5	19	38
P263540	54	318	4"	6"	54	102	41	78	50	35	13.5	20	42
P263600	60	393	4"	6"	60	108	41	82	51	36	14	21	46
P263660	66	475	6"	6"	66	114	49	86	59	41	16	22	54
P263720	72	565	6"	6"	72	120	49	88	60	42	16.5	23	55
P263780	78	664	6"	6"	78	128	49	89	61	42	17	24	59
P263840	84	770	6"	8"	84	134	49	90	61	43	18	25	64
P263900	90	884	8"	8"	90	145	60	108	69	48	19	27	68
P263960	96	1005	8"	8"	96	152	60	116	69	49	20	28	72

NOTE: All dimensions are approximate and must be field verified.

NOTE: Dimensions are for standard system configuration. Options, such as Fresh Water Backwash, add to overall length.

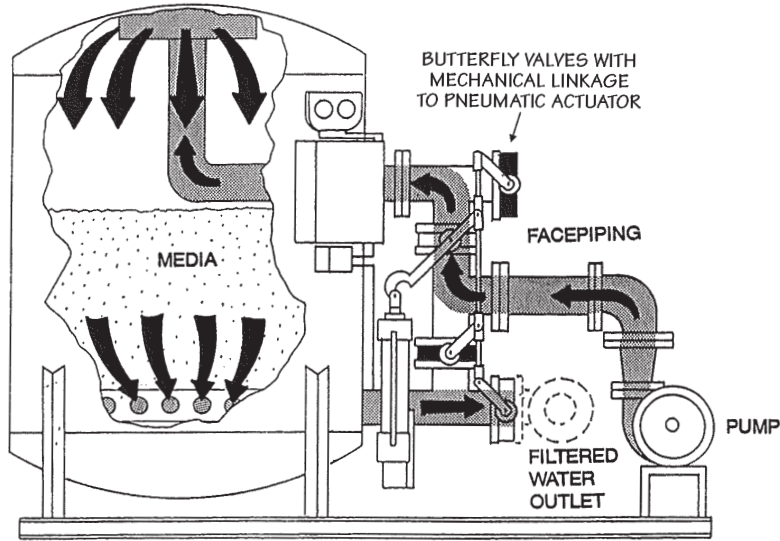

FILTER MODE

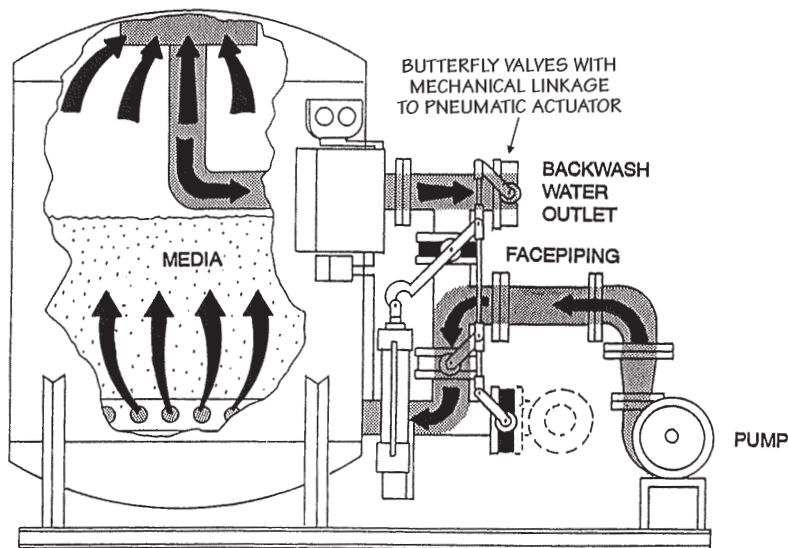

BACKWASH MODE

Let's say your filter system is installed in one of the two most common ways; either on:

- 1) an independent side stream from the cold water basin of the cooling tower with the filter situated below the static water level in the cooling tower; or
- 2) a slip stream from condenser water recirculation piping with the filter receiving influent water under pressure.

Let's say, like most filter systems, it uses electric valve actuation.

Then let's say your filter goes into backwash and suddenly you lose electrical power to the filter system. Your filter's valves are open to waste until the power comes back on. Unless you made provisions for backwash fail/safe in your filter installation (per the first warning statement in Step 1 of the installation instructions for all Tower-Flo filters that are equipped with electric actuation), you are going to continue to lose condenser water to drain until power is restored. If power is off for very long, it is very likely that your make-up valve will be wide open and you will still drain your tower dry.

Tower-Flo's standard Series TFB pneumatic actuation system is designed to provide integral backwash fail/safe protection. In the event of a loss of power during a backwash operation, TFB filters with pneumatic actuation, will fail back to their normal filter position preventing siphoning of condenser water to waste and eliminating the risk of draining a cooling tower dry.

The four-way air solenoid valve and the dual acting pneumatic cylinder work together to create this fail/safe. In filter mode, the four-way valve routes compressed air to the top side of the cylinder. For backwash, the four-way valve is energized; air is routed to the bottom of the cylinder; the cylinder rod is extended, and the linkage moves the valves to backwash position. If power is interrupted, the four-way valve fails to the position that routes air back to the top of the cylinder, the rod retracts, and the valves are moved back to filter position by the compressed air.

Backwash fail/safe, another better design standard from Tower-Flo Filters.

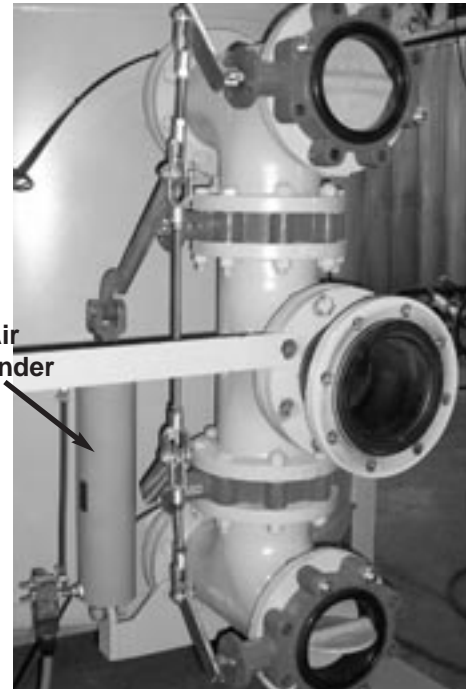

Series TFB pneumatic actuation system in filter position

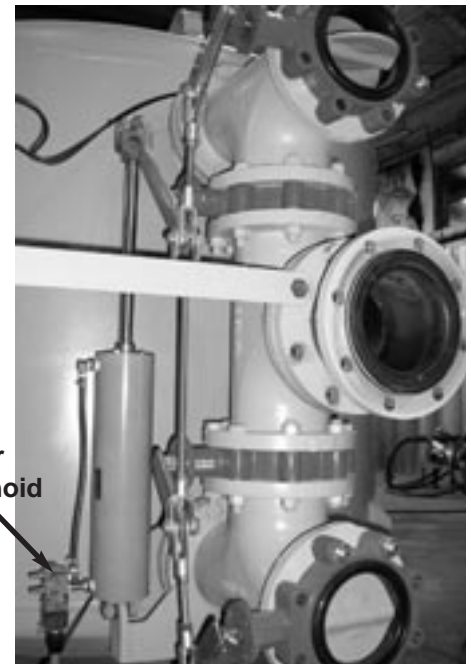

And in backwash position.

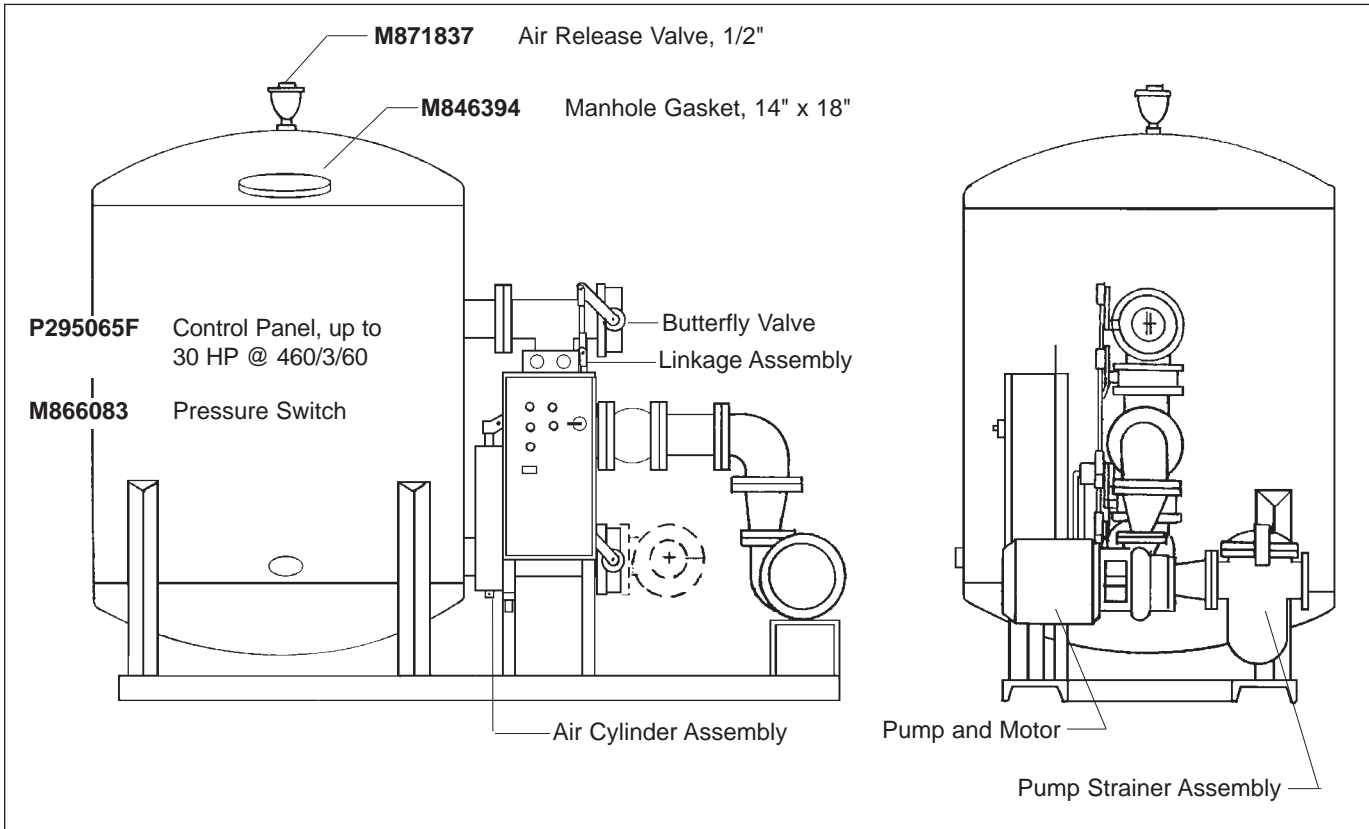

- M711529** Air cylinder assembly, 3"
- M711539** Air cylinder assembly, 4"
- M711567** Air cylinder assembly, 6" & 8"
 - M765090 Hose barb, brass, 1/4"mpt x 1/4" (all)
 - M820189 Bushing, brass, .5" x .25" txt (all)
 - M846409 Muffler, brass, 1/8", adjustable (all)
 - M846450 Nipple, brass, .25" x 2" tbe (all)
 - M855880 Cotter pin, SS, 1/8" x 1", long, (all)
 - M864414 Air cylinder, 4" bore x 11" stroke, 3"
 - M864415 Air cylinder, 4" bore x 12" stroke, 4"
 - M864416 Air cylinder, 4" bore x 14" stroke, 6" & 8"
 - M864417 Mounting Kit for air cylinder (all)
 - M865409 Clevis pin (all)
 - M865410 Rod clevis & jam nut (all)
 - M870220 Valve, 4-way, 120V
 - M870221 Valve, 4-way, 24V
 - M902520 Elbow, brass, street, 90°, 1/4" (all)
 - P035185 Hose, high pressure, 1/4" black, all
 - P059504 Clamp, hose (all)

Access Manhole

- M846421 Manhole cover, 14" x 18" double yoke
- M846395 Yoke, nut & bolt for 14" x 18" manway two required.

- P181040** Pressure gauge panel, 0-60 PSI
 - M842510 Fitting, brass 1/4" fpt x 1/4" tube
 - M902520 Elbow, brass street 90° 1/4"
 - P052452 Screw, S.S. button head 8-32 x 1/2"
 - P181045 Gauge press 0-60 PSI 3-1/2" back mount

- M710233** Linkage assembly, 3"
- M710244** Linkage assembly, 4"
- M710266** Linkage assembly, 6"
- M710288** Linkage assembly, 8"
 - M804800 All thread, 1/2-NF, plated, all
 - M811901 Nut, pltd, 1/2-20, all
 - M874200 Yoke ends 2708-6A, all
 - M874610 Yoke pins 2708 1/2-6A, all
 - M874400 Yoke ends 2708-6D, all
 - M874611 Yoke pins 2708 1/2-6D, all

Valves

- M870661 3" butterfly valve
- M870781 4" butterfly valve
- M870881 6" butterfly valve
- M870991 8" butterfly valve



Series
TFB

Parts

Pump and Motor Assembly

Part#	Model	GPM @ TDH	Disch	x	Suct	Strainer	HP
P263373	TFB-36	141 @ 53"	2"		2.5"	3"	3
P263430	TFB-42	192 @ 40'	2-1/2"		3"	3"	3
P263484	TFB-48	250 @ 42'	2-1/2"		3"	4"	5
P263549	TFB-54	318 @ 41'	3"		4"	6"	5
P263610	TFB-60	393 @ 40'	3"		4"	6"	7.5
P263664	TFB-66	475 @ 40'	3"		4"	6"	7.5
P263730	TFB-72	565 @ 40'	4"		5"	6"	10
P263790	TFB-78	664 @ 40'	4"		5"	6"	10
P263850	TFB-84	770 @ 40'	6"		6"	8"	15
P263910	TFB-90	884 @ 40'	6"		6"	8"	15
P263969	TFB-96	1005 @ 42'	6"		6"	8"	15

Pump Pre-Strainer Assembly

- P172853 3" flanged basket strainer with stainless steel basket
- P172854 3" stainless steel basket (replacement)
- P172855 4" flanged basket strainer with stainless steel basket
- P172856 4" stainless steel basket (replacement)
- P172858 5" flanged basket strainer with stainless steel basket
- P172859 5" stainless steel basket (replacement)
- P172860 6" flanged basket strainer with stainless steel basket
- P172861 6" stainless steel basket (replacement)
- P172868 8" flanged basket strainer with stainless steel basket
- P172869 8" stainless steel basket (replacement)



United Industries, Inc.
P.O. Box 58
Sterling, KS 67579
800-835-3272 • 620-278-3160
Fax 800-500-3115 • 620-278-3115
www.towerflo.com

Form TFB-PTS2:12/09

Data presented here is the best available at the time of publication. United Industries and/or its representatives assume no liability for its use.



Series
TFB

Parts-Controls

Control Panel, Complete Assembly

P295065F TFB, auto backwash control panel up to 30 HP @ 460V (must add correct Trip Module)

Control Panel - Major Components

Part #	Qty	Type	Description & Application
P263126	1	H-PKZ2	Handle, Disconnect Switch
P263125	1	AH-PKZ2	Shaft Extension, Disconnect Switch
P263152	1	PKZ2	Switch Module, Disconnect Switch
P263148*	*	ZM-1.6-PKZ2	Trip Module, 1.0-1.6 FLA*, Disconnect Switch
P263149*	*	ZM-2.4-PKZ2	Trip Module, 1.6-2.4 FLA*, Disconnect Switch
P263150*	*	ZM-4-PKZ2	Trip Module, 2.4-4.0 FLA*, Disconnect Switch
P263153*	*	ZM-6-PKZ2	Trip Module, 4.0-6.0 FLA*, Disconnect Switch
P263154*	*	ZM-10-PKZ2	Trip Module, 6.0-10.0 FLA*, Disconnect Switch
P263151*	*	ZM-16-PKZ2	Trip Module, 10.0-16.0 FLA*, Disconnect Switch
P263155*	*	ZM-25-PKZ2	Trip Module, 16.0-25.0 FLA*, Disconnect Switch
P295090	1	B100MBT713XK100VA	Transformer
P295191	1	M22-WKV	Selector switch operator
P295126	1	M22-D-S	Pushbutton operator
P295192	2	M22-AK10	Contact block
P295085	1	Counter	Backwash Counter

*NOTE: One thermal/magnetic trip module is provided, matched to the HP & primary voltage supply.

Pressure Switch

M866083 Differential pressure switch



United Industries, Inc.
P.O. Box 58
Sterling, KS 67579
800-835-3272 • 620-278-3160
Fax 800-500-3115 • 620-278-3115
www.towerflo.com

Form TFB-PTS-CNTL:12/09

Data presented here is the best available at the time of publication. United Industries and/or its representatives assume no liability for its use.

TOWER-FLO® Filters are equipped to automatically backwash using water from the same source they are filtering. In the vast majority of sidestream applications this is perfectly satisfactory. However, in some cases it is not desirable to dispose of system water for filter backwashing. In those cases, TOWER-FLO® offers two alternative approaches on Series TFB Filter as described below and on the following page.

FRESH WATER BACKWASH FROM MUNICIPAL SUPPLY

This option uses municipal water supply for backwashing. When the filter's differential pressure switch activates backwash, the system pump is stopped for the duration of the backwash operation and a valve is opened to allow city water to backwash the vessel. The flow rate and pressure of the city water supply must be controlled so as to not exceed the limits of the vessel; conversely, the flow rate must meet the vessel's minimum backwash flow requirement of 75% of flow rate.

Additional equipment provided with fresh water backwash from municipal supply includes a duplex valve, a pneumatic actuator with spring return, valve linkage and a flow control valve. The duplex valve with actuator is factory installed between pump discharge and filter facepiping (as shown at right) and will add 6" to 10" to the overall length of the filter assembly depending on filter and facepiping size. Air supply connections are also factory installed. The flow control valve must be field installed, by others, in the municipal supply line before connection to inlet of the duplex valve to limit backwash to the desired flow rate.

The end-user is also responsible for the addition of a pressure-controlling device in the fresh water supply line set to a maximum 30 psi. Local code may also require the end-user to add a back flow preventer in the fresh water supply line.

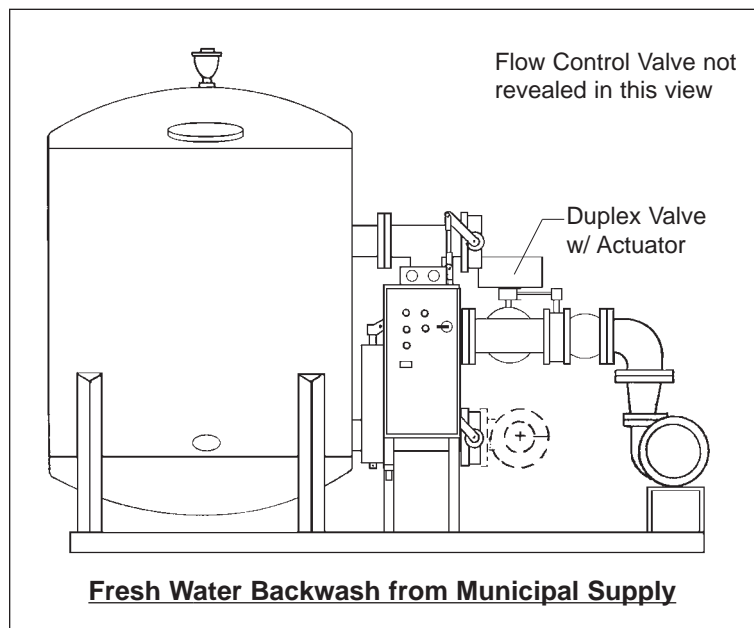

Backwash will occur as described in the OPERATION section of this manual, with one exception. When the system executes a backwash operation - either automatic or manual - the recirculation pump will not come on during the actual backwash period, rather the duplex valve will be actuated allowing municipal water supply to achieve backwash.

FRESH WATER BACKWASH FROM STATIC SUPPLY, PUMP ASSISTED

This option uses a totally independent, static water supply (such as an accumulation vessel) for backwash source water and relies on the filter's pump to create the backwash flow from that static source. This option is useful when it is not desirable to backwash with system water and municipal supply is either not available or cannot meet the minimum flow requirement.

Additional equipment provided with fresh water backwash from static supply includes a three-way butterfly valve, a pneumatic actuator with spring return, valve linkage, and factory installed air supply hose connections installed in front of pump suction as shown below. This assembly may have to be removed for shipping and field re-installed.

Backwash will occur as described in the OPERATION section of this manual, with one exception. When the system executes a backwash operation - either automatic or manual - the duplex valve will be actuated, at the same time as the system valves, to change the source from which the pump will draw for backwash.

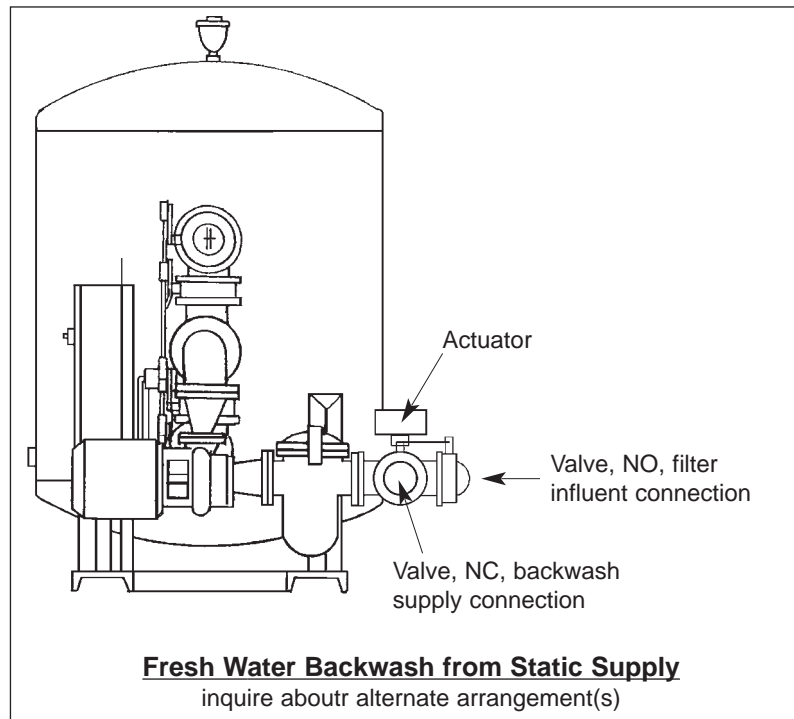



Installation Issues

INSTALLATION STYLE

Tower-Flo® generally recommends **sidestream** installation of its filter systems and its standard systems are designed and built for **sidestream** application. **Sidestream** filtration means a filter system which draws water from and returns it to a static pressure reservoir of water in the cooling loop, completely independent of the cooling water recirculation system. Usually, that reservoir of water is the basin of the cooling tower or sometimes it may be a chilled water storage reservoir in the cooling loop.

However, there are occasions where a design has called for **slipstream** installation. **Slipstream** filtration means a filter which is installed on the pressurized recirculation piping system, "slipping" a portion of the chilled water recirculation flow through the filter system. Depending on the points of connection to the recirculation piping, the **slipstream** may be either under the influence of the discharge side or the suction side of the recirculation pump.

If the filter system you are about to install is to be installed in any other fashion than sidestream, please be sure that necessary consideration has been given to operating pressure of the filter system and flow promotion issues. If you, as the installer, have any questions, contact your local Tower-Flo® Representative or contact the Tower-Flo® Water Filter Systems Division of United Industries, Inc.

BASIN SWEEPER PIPING SYSTEM

A basin sweeper piping system will use the return flow of filtered water from the filter system to help sweep solids towards the filter's suction point. However, it is very important to have a reasonable expectation of such a basin sweeper piping system. It must be understood that the primary purpose of the filter system is the continuous removal of suspended solids from the water being recirculated through the cooling loop. The basin sweeper piping system provides a secondary benefit by promoting the movement solids across the basin floor toward the filter suction point for removal.

While such a system can reduce the time and effort required for regular basin clean-out, even the best designed sweeper piping system cannot keep a cooling tower basin perfectly clean nor sweep effectively around all appertances. If you plan to use a basin sweeper piping system, please review the information on the next page to determine the proper number of nozzles or perforations to be used with your basin sweeper piping system.

IF YOU, AS THE INSTALLER OR OWNER OR OPERATOR, HAVE ANY QUESTIONS ABOUT ANY ASPECT OF YOUR INSTALLATION AND/OR OPERATION OF THIS TOWER-FLO® FILTER SYSTEM, CONTACT YOUR LOCAL TOWER-FLO® REPRESENTATIVE OR CONTACT THE TOWER-FLO® WATER FILTER SYSTEMS DIVISION OF UNITED INDUSTRIES, INC., BEFORE START-UP OF THIS FILTER SYSTEM.



United Industries, Inc.
P.O. Box 58
Sterling, KS 67579
800-835-3272 • 620-278-3160
Fax 800-500-3115 • 620-278-3115
www.towerflo.com

Form INISS:4/98

Data presented here is the best available at the time of publication. United Industries and/or its representatives assume no liability for its use.



Basin Sweeper Piping

DISCHARGE OPENINGS: The sizing of holes in a basin sweeper piping system evolves from the decision of the *type* of DISCHARGE openings to be used; either simple holes, sweeper-educator nozzles, or a combination of those two types. Different criteria must be used to determine the number of discharge holes and/or nozzles to be used for a given application, as follows:

HOLES ONLY: The total open area of discharge line openings should be equal to or slightly greater than the total open area of the discharge pipe size. Use the table or the formula below to determine the size and number of holes to be used.

NOZZLES ONLY: The total number of nozzles will be the flow rate of the filter system divided by 5 gpm per nozzle.

COMBINATION OF NOZZLES & HOLES:

- 1) start with the filter flow rate.
- 2) determine the preliminary number of nozzles you want to use.
- 3) multiply that number of nozzles by 5gpm per nozzle.
- 4) subtract the outcome of 3) from the total flow rate of the filter system (this is the portion of the filter flow rate consumed by nozzles; this number cannot exceed the filter's flow rate; if it does, return to the nozzle only instructions).
- 5) divide the remaining flow rate by 3 gpm to determine the number of **1/4"** holes to be used in conjunction with the nozzles.

SUCTION OPENINGS: Irrespective of the *type* of discharge openings selected, the number and size of suction openings will **always** be determined by the following: the total open area of suction line openings should be equal to or slightly greater than 125% of the total open area of the discharge pipe size.

TO CALCULATE NUMBER AND SIZE OF DISCHARGE AND SUCTION OPENINGS

- Steps:
- 1 Calculate open area of selected discharge pipe size based on its inside diameter (πr^2);
 - 2 Calculate open area of selected discharge hole size (πr^2);
 - 3 Divide result of Step 1 by result of Step 2 to find number of holes in discharge piping (round up);
 - 4 Multiply result of Step 3 by 1.25 to find number of suction holes (round up).

The calculated number of discharge openings should be spaced evenly around the discharge pipe run or across pipe runs designed to influence specific areas. Suction holes should be spaced evenly around the suction header in the water basin or reservoir. Common sense should always govern the selection of hole sizes, the resulting number of holes, and the placement of those openings; keep the number of holes to be drilled to a practical, manageable number for the run of pipe.

The tables below will help you select the size and number of holes for most Series TF, TFD, TFD2, and TFH installations. The Inside Diameter Table provides the information necessary for you to calculate hole sizes and number for other installations.

Inside Diameter of Common Pipe Sizes							
	1.5"	2.0"	2.5"	3.0"	4.0"	6.0"	8.0"
Sch 40	1.610	2.067	2.469	3.068	4.026	6.065	7.981
Sch 80	1.500	1.939	2.323	2.900	3.826	5.761	7.625

Suggested Number of Pipe Holes												
PIPE SIZE	SCH 40						SCH 80					
	# 1/4" holes		#3/8" holes		# 1/2" holes		# 1/4" holes		#3/8" holes		# 1/2" holes	
	DIS	SUC	DIS	SUC	DIS	SUC	DIS	SUC	DIS	SUC	DIS	SUC
1.5"	50	63	19	24	11	14	36	45	16	20	9	12
2"	68	85	31	39	18	23	61	77	27	34	16	20
2.5"	98	123	44	55	25	32	87	109	39	49	22	28
3"	•	•	67	84	38	48	•	•	60	75	34	43
4"	•	•	116	145	65	85	•	•	104	130	59	74
6"	•	•	•	•	148	185	•	•	•	•	133	167
8"	•	•	•	•	255	319	•	•	•	•	233	292



United Industries, Inc.
 P.O. Box 58
 Sterling, KS 67579
 800-835-3272 • 620-278-3160
 Fax 800-500-3115 • 620-278-3115
 www.towerflo.com

Data presented here is the best available at the time of publication. United Industries and/or its representatives assume no liability for its use.

Form SWEEP:4/98

STEP 1. UNPACK AND INSPECT THE FILTER

New Tower-Flo® Series TFB Filters should have been unwrapped and thoroughly inspected for freight damage upon receipt at your receiving dock, per the receiving stickers affixed to the filter's protective shrink-wrap. Freight damage issues must be addressed with the freight carrier when accepting delivery.

As you prepare to install your filter, confirm that you have:

- 1) the skid mounted filter system;
- 2) several skids of filter rock, gravel and sand media corresponding to the quantities shown on the Project Specifications, found on page 6 of this manual, for your size filter system .
- 3) a card board box or boxes on one of the media skids that contains the filter vessel's collection laterals, air release valve, and air release piping components.
- 4) One quart container and one pint container which are the two parts of the polyurethane exterior coating for touch-up after installation; mix and use, not storable once mixed.

Re-inspect the filter system to check that all plumbing connections are tight and that there are no cracks or fractures in any of the external piping.

STEP 2. LOCATE FILTER

Place the TOWER-FLO® Filter System on a firm level surface. The TOWER-FLO® Filter does not need to be anchored, unless required by local code. Select a location close to the cooling tower to allow for convenience, accessibility and serviceability. If the filter is to operate year-round, exposure to winter conditions should be a consideration in your location decision.

WARNING

If your TOWER-FLO® is to be installed BELOW the static water level of the tower sump:

- 1) Install valves on the inlet, waste and outlet piping to permit isolation of the filter system for service.

WARNING

TOWER-FLO® Filters should never be installed on a dirty basin or reservoir. Installing the filter on a dirty basin will cause a nearly constant backwash condition. Always clean accumulated mud, silt, and debris from the bottom of the basin or reservoir BEFORE installation of the sidestream filter.

STEP 3. PLUMBING

- A) Fabricate and install sweeper piping system in water source with holes sized according to the Sweeper Pipe Sizing tables and formula found on page 10 of this manual; or if using TOWER-FLO® Sweeper-Eductor Nozzles, follow directions supplied with the nozzles. The sweeper piping system should be designed so that water returning from the filter sweeps particulate matter toward the suction line to the filter which is usually installed at or near the lowest point in the source water basin.
- B) Assemble and install the automatic and manual air release piping as shown at right.

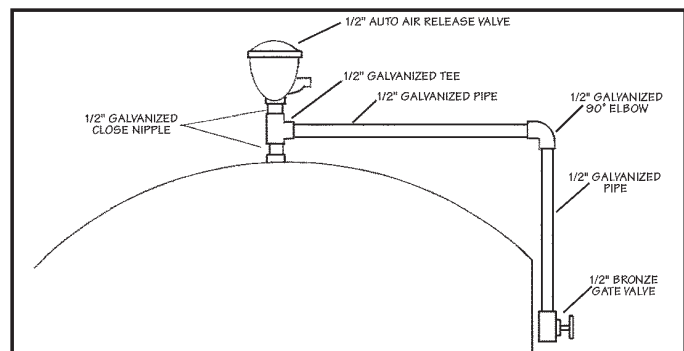

TFB Automatic and Manual Air Release Assembly

STEP 3. PLUMBING continued

- C) Connect piping from water source to strainer inlet*.
- D) Install return piping from filter's effluent (filtered water) valve outlet to water source*.
- E) Install waste piping from backwash outlet valve to drain. The backwash sight glass shipped with the unit should be installed in the waste line (as shown at right) in a position which allows convenient observation of backwash flow. Make certain the disposal point will handle the unit's stated backwash flow. **NOTE:** Backwash flow requirements must be maintained to insure adequate cleansing effect.
- F) To permit drainage of filter system for winterization, add drain valve at lowest point in side stream piping.

*TOWER-FLO® recommends the installation of unions and/or valves in these three plumbing connections for ease of isolation or removal, should it become necessary for any reason. All plumbing connections should follow accepted plumbing procedures. Pipe joints should be sealed using teflon tapes without adhesive backings or with compounds suitable for use with PVC and ABS plastics.

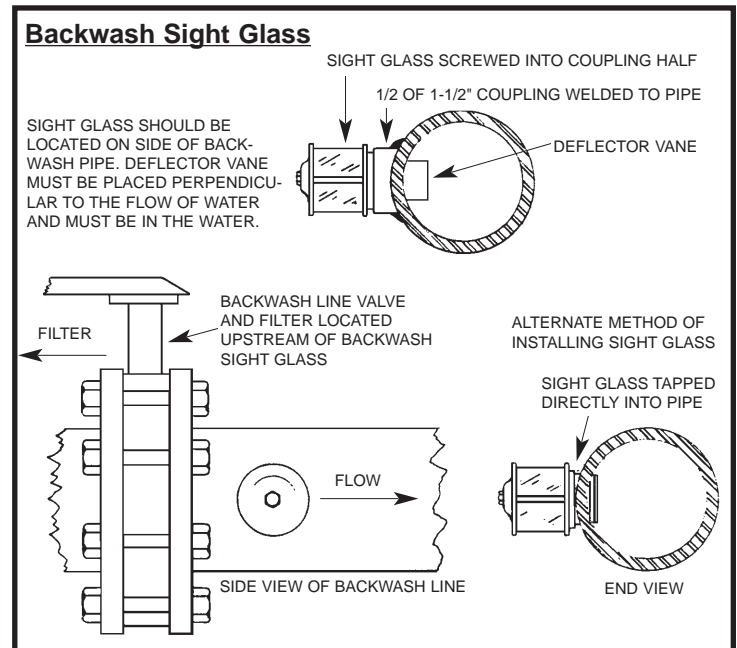

STEP 4. COMPRESSED AIR

Standard TFB filters require plant air supply to be field connected to the 1/4" hose barb connection on the air filter/regulator which is mounted on the filter's control panel bracket.

Optionally, the filter may be supplied with an air compressor (not suitable for outdoor installation) which has been:

- factory mounted on filter base requiring 120/1/60 power supply by others; or
- factory mounted on filter base, power supplied through the filter control panel with no further field requirements; or
- boxed for field location and installation by others and requiring 120/1/60 power supply by others.

STEP 5. ELECTRICAL

All TOWER-FLO® systems are pre-wired at the factory and require only field connection of the primary power supply as indicated on the order, the filter paperwork, and the filter serial number data plate affixed to the interior of the filter control panel. The program of operation and wiring diagrams will vary by the operating requirements for each filter unit. Follow directions shown on wiring diagram provided with unit. Proceed as follows:

- A) Check power supply wiring and related components for compatibility with system making sure local code requirements are met.
- B) Make all contacts according to the wiring schematic provided with the unit.

STEP 6. LATERAL ASSEMBLY

Each Tower-Flo® system is delivered with inlet and outlet headers attached. However, to avoid damage during shipping, the **outlet laterals are not installed**. Complete the following for proper lateral installation:

- 1) At the discretion of the installer or owner, fill bottom of vessel below outlet header with either the required quantity of P166090 filter rock, 1/4" to 1/2" in size, or standard grade concrete. Concrete will increase vessel stability, however, concrete is not supplied by Tower-Flo®. The required quantity of rock or concrete to fill the bottom of the vessel below the laterals is shown on the next page. **NOTE:** If installing a TFB-C filter system, use of concrete fill is strongly recommended.
- 2) Whether using rock or concrete for fill, it is recommended that masking tape be applied over holes in the header to prevent rock or concrete from entering the header during the filling process.
- 3) When fill reaches the bottom of the outlet header, remove masking tape from holes and install laterals by turning male threaded end of lateral into female threaded hole in header until tight. The exact number and length of laterals supplied with each filter system, along with the size of its facepiping and outlet header, is shown below. Laterals install in order from top to bottom as listed below for your specific filter size, starting at the outside or capped end of the header, one lateral on each side of the header, and progressing to the outlet end of the header.

TFB-42	3"
2 @ 9"	
2 @ 12"	
2 @ 14"	
2 @ 15"	
2 @ 15"	
2 @ 14"	
2 @ 12"	
2 @ 11"	
TOTAL 16	

TFB-48	4"
2 @ 11"	
2 @ 13"	
2 @ 15"	
2 @ 17"	
2 @ 17"	
2 @ 17"	
2 @ 17"	
2 @ 15"	
2 @ 13"	
TOTAL 18	

TFB-54	4"
2 @ 12"	
2 @ 15"	
2 @ 17"	
2 @ 19"	
2 @ 20"	
2 @ 20"	
2 @ 20"	
2 @ 19"	
2 @ 17"	
2 @ 15"	
2 @ 12"	
TOTAL 22	

TFB-60	4"
2 @ 13"	
2 @ 17"	
2 @ 19"	
2 @ 21"	
2 @ 22"	
2 @ 23"	
2 @ 23"	
2 @ 23"	
2 @ 23"	
2 @ 22"	
2 @ 21"	
2 @ 19"	
2 @ 17"	
TOTAL 24	

TFB-66	6"
2 @ 13"	
2 @ 17"	
2 @ 21"	
2 @ 22"	
2 @ 24"	
2 @ 25"	
2 @ 25"	
2 @ 25"	
2 @ 25"	
2 @ 25"	
2 @ 25"	
2 @ 24"	
2 @ 22"	
2 @ 17"	
TOTAL 26	

TFB-72	6"
2 @ 14"	
2 @ 19"	
2 @ 22"	
2 @ 24"	
2 @ 26"	
2 @ 27"	
2 @ 28"	
2 @ 28"	
2 @ 28"	
2 @ 28"	
2 @ 28"	
2 @ 27"	
2 @ 26"	
2 @ 24"	
2 @ 22"	
2 @ 19"	
TOTAL 30	

TFB-78	6"
2 @ 15"	
2 @ 23"	
2 @ 26"	
2 @ 28"	
2 @ 29"	
2 @ 30"	
2 @ 31"	
2 @ 31"	
2 @ 31"	
2 @ 31"	
2 @ 31"	
2 @ 31"	
2 @ 30"	
2 @ 29"	
2 @ 28"	
2 @ 26"	
2 @ 23"	
2 @ 20"	
TOTAL 32	

TFB-84	6"
2 @ 16"	
2 @ 21"	
2 @ 25"	
2 @ 27"	
2 @ 30"	
2 @ 31"	
2 @ 33"	
2 @ 34"	
2 @ 34"	
2 @ 34"	
2 @ 34"	
2 @ 34"	
2 @ 34"	
2 @ 33"	
2 @ 31"	
2 @ 30"	
2 @ 27"	
2 @ 25"	
2 @ 21"	
TOTAL 36	

TFB-90	8"
2 @ 17"	
2 @ 25"	
2 @ 28"	
2 @ 31"	
2 @ 32"	
2 @ 34"	
2 @ 35"	
2 @ 36"	
2 @ 36"	
2 @ 36"	
2 @ 36"	
2 @ 36"	
2 @ 36"	
2 @ 36"	
2 @ 35"	
2 @ 34"	
2 @ 32"	
2 @ 31"	
2 @ 28"	
2 @ 22"	
TOTAL 36	

TFB-96	8"
2 @ 18"	
2 @ 27"	
2 @ 30"	
2 @ 32"	
2 @ 34"	
2 @ 36"	
2 @ 37"	
2 @ 38"	
2 @ 39"	
2 @ 39"	
2 @ 39"	
2 @ 39"	
2 @ 39"	
2 @ 38"	
2 @ 37"	
2 @ 36"	
2 @ 34"	
2 @ 32"	
2 @ 30"	
2 @ 23"	
TOTAL 38	



Series
TFB

Installation

CAUTION

Extreme care must be taken while installing filter media to prevent damage to the lateral assembly.

STEP 7. FILTER MEDIA LOADING

- A) Confirm that the vessel drain plug in the bottom of the vessel and the hand hole in the side of the vessel are in place and secured.
- B) Fill the tank with enough water to just cover underdrain laterals. This water will act as a buffer to protect laterals during media loading.
- C) With one person outside the vessel handing media in manageable quantities to another person inside the vessel, gently "float" media under and around the laterals until they are completely covered, then slowly add the rest of the media provided with the unit as shown below.
- D) Replace and secure the manway cover.

MEDIA REQUIREMENTS BY MODEL NUMBER

Model #	Concrete or Rock (1/4"-1/2") Fill	Rock 1/4"-1/2"	Gravel 1/8"-1/4"	Sand .45mm-.55mm	Pipe Size
TFB-36	na	na	na	14	3
TFB-42	3	5	3	18	3
TFB-48	5	12	4	23	4
TFB-54	7	14	4	29	4
TFB-60	10	17	5	35	4
TFB-66	14	22	6	42	6
TFB-72	19	24	8	52	6
TFB-78	23	30	9	59	6
TFB-84	28	34	10	68	6
TFB-90	33	40	12	80	8
TFB-96	39	44	14	96	8

NOTE

1 Cubic Foot of any of the above media = 100 lbs



United Industries, Inc.
P.O. Box 58
Sterling, KS 67579
800-835-3272 • 620-278-3160
Fax 800-500-3115 • 620-278-3115
www.towerflo.com

Data presented here is the best available at the time of publication. United Industries and/or its representatives assume no liability for its use.

Form TFB-INSTAL4:2/10

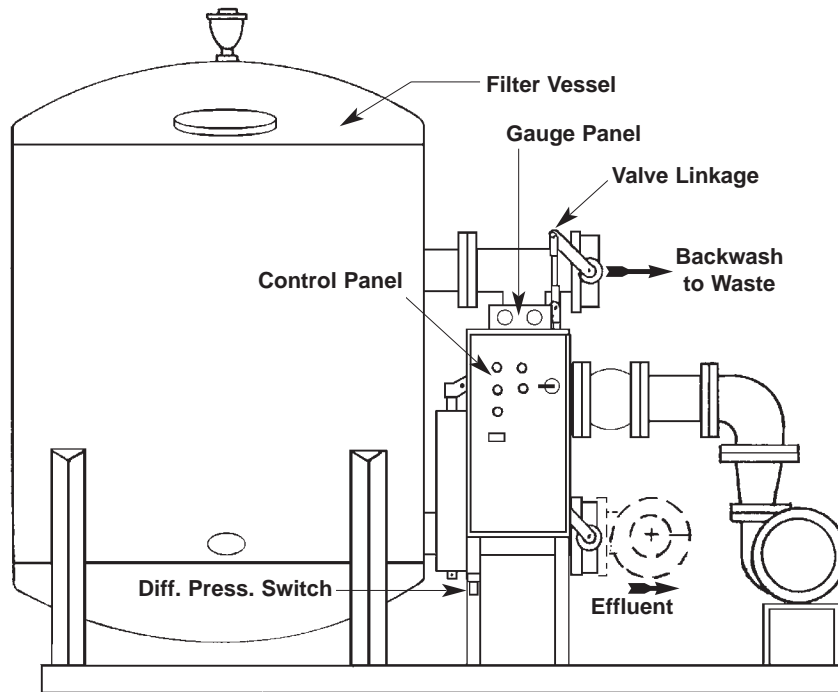

NOTE

New or refurbished water circulation systems commonly contain debris associated with construction. All pump suction and return lines as well as cooling tower pan/sump should be thoroughly flushed prior to start up.

WARNINGS

THIS SYSTEM OPERATES UNDER PRESSURE AND SHOULD NEVER BE OPENED UNTIL THE PUMP IS SHUT OFF AND THE PRESSURE IS BLEED OFF THROUGH THE AIR RELIEF VALVE.

Never operate filter at pressures over 50 psi. Such pressures indicate need for complete cleaning or a malfunction. The filter system is designed to withstand water temperatures up to 120°F/49°C.

START-UP PROCEDURE

Following completion of all previously scheduled installations, proceed with start-up as follows:

- 1) Verify that drain plugs in filter vessel, pump and pump strainer are secured.
- 2) Verify plant air supply connection to air filter/regulator and regulator setting at 80 psi. If optional air compressor was supplied, verify operation of air compressor and outlet pressure setting at 80 psi.
- 3) Confirm system valves in filter position (air cylinder retracted).
- 4) Open manual air release valve.
- 5) Open any/all isolation valves in suction and return lines.



Series
TFB

Start Up

START-UP PROCEDURE con't

- 6) Allow piping, pump, and filter vessel to fill with water. Air in the system will forced out through the manual air release valve.
- 7) Close the manual air relief valve when a steady stream of water flows from the valve -- this indicates that all air has been bled from the tank.
- 8) Start the pump by turning the main power disconnect switch on the face of the control panel to the on position.and turning the ON/OFF motor contactor switch to the on position **There will be a 30 second time delay before the pump starts** (this delay will occur any time the system is restarted after a power interruption or disconnect).
- 9) Check proper pump rotation with arrow on pump housing by turning system on/off rapidly. If pump rotation is backwards, shut the system down and correct the electrical connection.
- 10) Check system plumbing for leaks and repair.
- 11) After allowing the system to filter for five to ten minutes, backwash the system, by pressing the manual backwash pushbutton, to clean out any construction debris and to consolidate the media bed.
- 12) If, after observing the backwash operation, you note that the valve actuation is too swift and causes water hammer in system piping, you can slow the valve actuation by adjusting the air exhaust rate at the two exhaust mufflers on the air solenoid valve located at the bottom of the air cylinder.
- 12) Your TOWER-FLO® is now in operation.
- 13) NOTE FILTER'S INFLUENT PRESSURE READING AT START UP AND RECORD FOR FUTURE REFERENCE.

Start Up Date	_____
Influent Pressure	_____
Effluent Pressure	_____

NOTE If your filter is equipped with optional Fresh Water Backwash from municipal supply, the pump does not come on in backwash

NOTE : Small grains of sand may leave the filter during backwashing or may even appear at the return line when the filter is first started. This is characteristic of permanent media filters and should clear up after the first few backwash cycles as the filter finds its operating freeboard level. Should sand continue to appear at the **return line** over time, this is evidence that a collection lateral was cracked or broken during media loading and that lateral must be replaced.



United Industries, Inc.
P.O. Box 58
Sterling, KS 67579
800-835-3272 • 620-278-3160
Fax 800-500-3115 • 620-278-3115
www.towerflo.com

Data presented here is the best available at the time of publication. United Industries and/or its representatives assume no liability for its use.

Form TFB-START2:2/10

AUTOMATIC BACKWASH

All permanent media filter systems have a difference in pressure between fluid entering the filter (influent) and the fluid exiting the filter (effluent). This pressure drop, commonly referred to as differential pressure or ΔP , will be approximately 3 psi when the filter media is clean. As system water passes through the media bed, particles in the water become trapped in the media. As the amount of trapped particles increases, so does the resistance to flow and the ΔP . As the filter becomes increasingly loaded with trapped particles, the influent pressure will increase and the effluent pressure will decrease.

Your Tower-Flo® filter is equipped with an automatic backwash control system. Primary initiation of an automatic backwash is by the ΔP switch, factory set to close on a 10 psi difference between the influent and effluent pressures. When this switch closes, a 30 second delay timer (T4) is initiated, and the switch must remain closed for the duration of that 30 second time delay before backwash is initiated. This prevents random pressure surges from initiating an unnecessary backwash.

Your Tower-Flo® filter's automatic backwash operation can also be initiated by two other means: 1) by depressing the manual backwash push button on the face of the control panel; or 2) by the 100-hour (field adjustable) "re-setting" backup timer (T5) which will force a backwash every 100 hours in the event that neither ΔP nor Manual initiated backwash has occurred (ΔP or manual initiation resets T5).

When any of these three backwash initiations occur, the programmable relay in the control panel will execute its pre-programmed timing sequence as described and time lined on the next page.

ALARM

The control panel on your Tower-Flo® filter is equipped with a ΔP switch repeat alarm (Timer T6). When an alarm condition occurs, the filter will automatically shut itself off, energize its alarm light, close the dry contacts provided for remote indication of alarm condition, and require manual attention at the filter's control panel to restart the filter system.

An alarm condition will occur:

- 1) If a ΔP switch closure tries to initiate a second backwash within 15 minutes after a previous ΔP switch initiated backwash.
- 2) If the ΔP switch gets stuck in the closed position.

The Alarm condition is cleared by rotating the ON/OFF switch on the face of the control panel. When an alarm occurs, the operator must investigate the cause of the alarm. The ΔP switch is normally open. Check continuity through the ΔP switch across control terminals #2 and #3. If there is no continuity, condition #1 exists indicating there is most likely a problem with the media bed and media inspection must be conducted. If there is continuity, condition #2 exists and the ΔP switch must be replaced.

AUTOMATIC BACKWASH OPERATION

The series of events controlling automatic backwash are described below. The programmable relay follows these steps and timer identifications in its program of operation.

1. Differential pressure switch closes, initiates Timer T4, and remains closed for 30 seconds.
2. Timer T4 elapses, or the manual backwash push button is pressed, or Timer T5 elapses, which initiates Timer T1 and Timer T2. Timer T1 energizes the control relay to the valve actuators changing the valves to backwash position. Timer T2 interrupts the pump motor contactor stopping the pump while the valves rotate.
3. Timer T2 elapses, pump motor contactor is re-energized restarting the pump. Filter is now in backwash mode for 3 minute flow time.
4. Timer T1 elapses, Timer T3 initiated. T3 interrupts pump motor contactor stopping the pump. Timer T1 de-energizes the control relay to the valve actuators changing the valves back to filter position.
5. Timer T3 elapses, pump motor contactor is re-energized restarting the pump. Filter is now back in filter mode.

BACKWASH TIME LINE

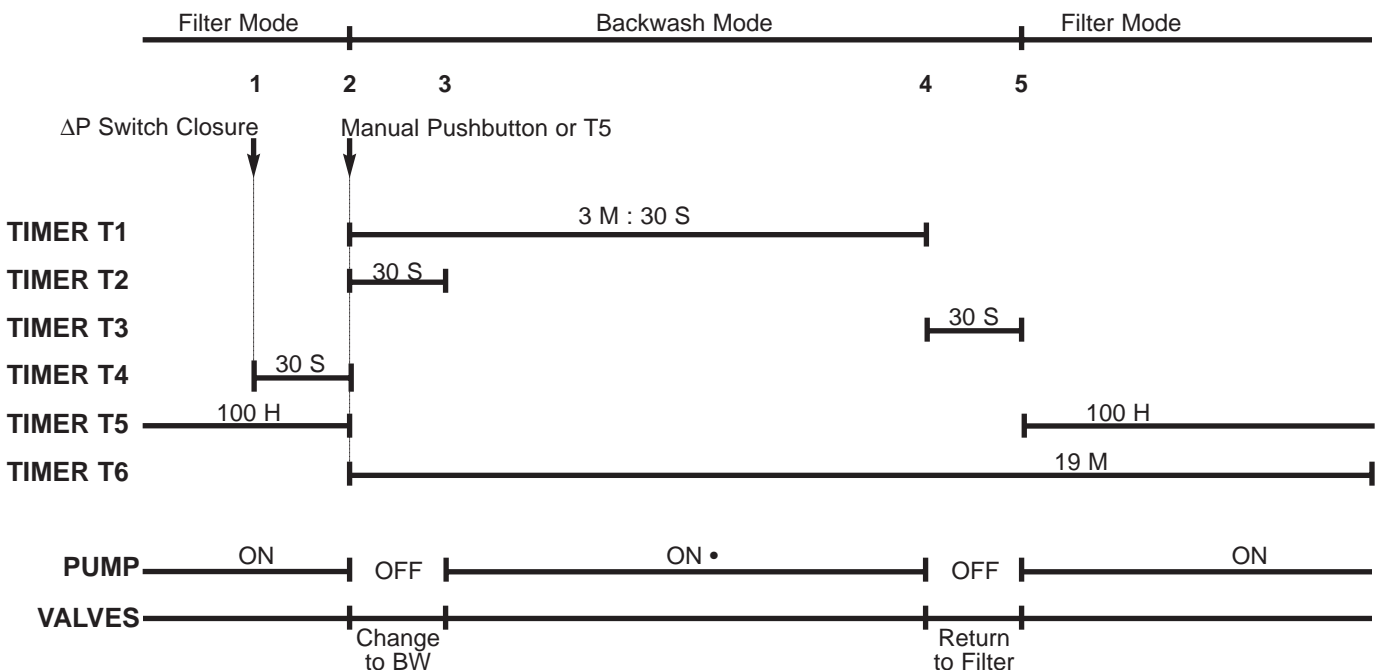

NOTE: Timers T5 and T6 are field adjustable through the PARAMETERS screen on the programmable relay. All other Timers are password protected and can only be changed with consultation from Tower-Flo®.

• **NOTE:** On filter systems equipped with optional fresh water backwash from municipal water supply, the pump is not energized for backwash. Factory setting of Timer T2 will be changed to 3:30.

The TOWER FLO filtration system is virtually maintenance free. The following are guidelines to ensure proper performance and increase longevity of the system.

WEEKLY

- 1) Check all plumbing connections for leakage.
- 2) Check all electrical connections and components for signs of malfunction or poor connection.
- 3) Lubricate moving parts, i.e. linkage, handles, air cylinder.
- 4) Check pressure gauges for proper operation.

MONTHLY

- 1) Place unit in "off" position.
- 2) Check automatic air release valve for proper operation, slowly remove plug in top of valve as some pressure may remain in system if valve is dysfunctional.
- 3) Remove manway cover and inspect media bed. **See Media Inspection instructions on Page 35.**

YEARLY

- 1) Inspect media bed for visible contamination or extraneous material. Media should be tested to a depth of 8" to 12".
- 2) Maintain proper level of media bed.



Media Inspection

The filter sand provided with your Tower-Flo® filter is permanent media and should never require replacement. However, the media bed will function as a “concentrator” of both problem filtrates that resist removal by backwash action, as well as water treatment deficiencies. Regular monthly media bed inspections will keep your filter operating properly and can alert you to emerging water chemistry issues.

Media bed inspection requires accessing the media. Turn off the pump, close isolation valves in influent and effluent piping to the filter, open the tank drain, open the air relief valve, release the band clamp on the filter vessel, remove the the tank lid, close the tank drain when the water level is low enough to expose the surface of the media bed.

Inspection is a three step process; smell, look, feel:

- Smell to see if the media smells clean. A “septic” smell would indicate the presence of live biological contaminants in the media bed and an issue with the biocide treatment. Sanitize the media bed with bleach.
- Look to see if the surface of the media bed is clean, smooth and flat. Remove any accumulation of fibrous materials (i.e., cottonwood tree seeds) or heavy materials that are not being removed by backwash action. The appearance of “ridges and valleys” on the surface of the media bed would indicate the beginning of hard spots down in the media bed (under the ridges) and an issue with water hardness control. Either remove the hardened media and replace with an equal volume of new sand or recondition media bed with a muriatic acid wash to dissolve calcium.
- Feel the sand at the surface to see if it is clean and loose. Probe the bed in several random places to a depth of 8 to 12 inches to see if it is clean, loose and free of evidence of foreign matter, mudballs, oilballs, or hard spots down in the media bed. If contamination is found, either remove the contaminated media and replace with an equal volume of new sand or recondition media bed with a muriatic acid wash to dissolve calcium or a low sudsing / low phosphate detergent to dissolve oilballs.

Resolution of problems revealed by your inspection requires the suggested remedies for the media bed (to treat the symptoms) as well as attention from those responsible for your water treatment / water chemistry program (to treat the problem).

After inspection, replace the vessel lid and the band clamp assembly by CAREFULLY AND EXACTLY following the Filter Clamp Installation Instructions decal permanently affixed to the vessel lid, open isolation valves and restart your filter system according to the Start-Up Instructions.

For **SEASONAL SHUTDOWN** of the TOWER-FLO® Filter System:

1. **ELECTRICAL:** Disconnect electrical power.
2. **PUMP:** Drain liquid from the pump through the plug at bottom front section of volute. Addition of a good rust inhibitor into liquid end of the pump is recommended to prevent corrosion. Be sure the motor is kept dry and covered.
3. **VESSEL & VALVES:** Drain vessel and valves by removing the drain plug in the bottom of the vessel.
4. **GAUGES & DIFFERENTIAL PRESSURE SWITCH:** Disconnect influent and effluent pressure lines at facepiping and allow to drain, then reconnect.
5. **PNEUMATIC ACTUATOR:** Disconnect pneumatic feed (if applicable).

For **YEAR-ROUND OPERATION** of the TOWER-FLO® Filter System:

In installations where freezing may occur, heat tracing of all slow moving or static lines, especially tubing to pressure gauges, differential pressure switch, and the air relief valve on the vessel, is highly recommended. Use standard insulation and freeze protection methods for your region.